

Avanti 77



AVANTI 77, JAW WIDTH 77 MM

ITEM NO.	BASE LENGTH	MAX. CLAMPING RANGE	WEIGHT	PRICE	COMPARABLE PREVIOUS VERSION
44120-77*	130 mm	125 mm	3.5 kg		44120
44160-77	170 mm	165 mm	4.2 kg		44160
44200-77	210 mm	205 mm	4.8 kg		44200

*automatable

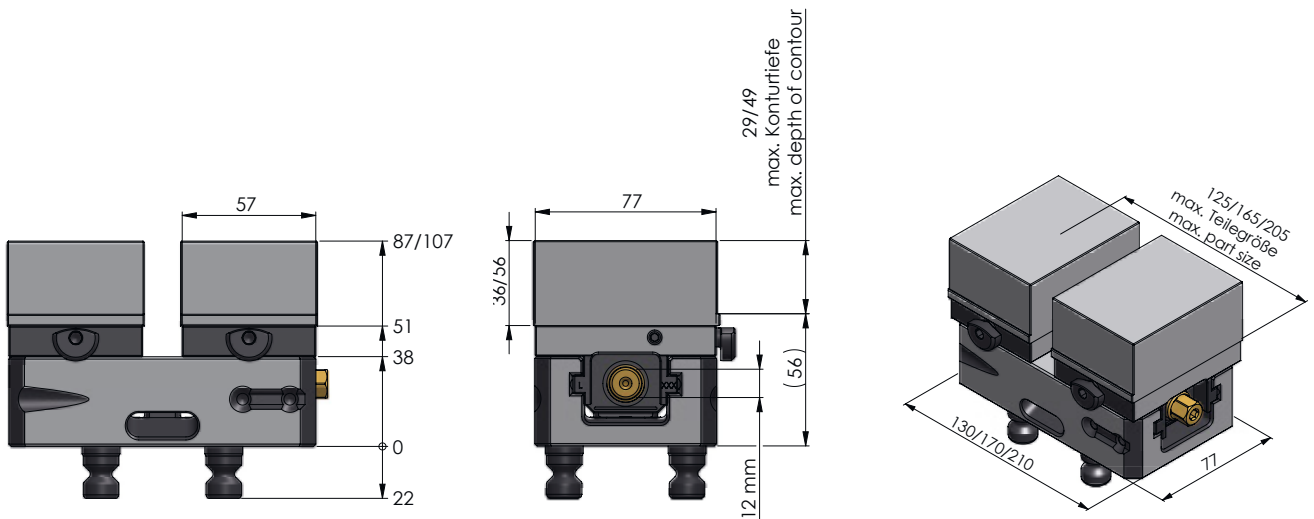

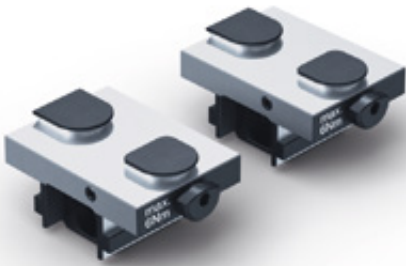

AVANTI 77 BASE JAWS, JAW WIDTH 77 MM

ITEM NO.	DIMENSIONS	WEIGHT	UNIT	PRICE	COMPARABLE PREVIOUS VERSION
44771-77	77 × 57 mm	1.4 kg	1 pair		44771

NEW

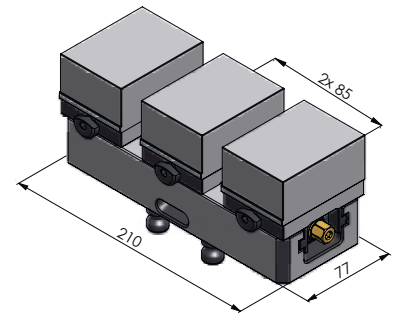
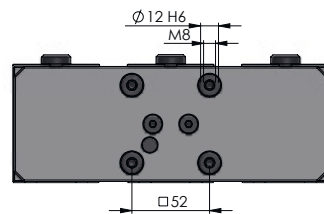
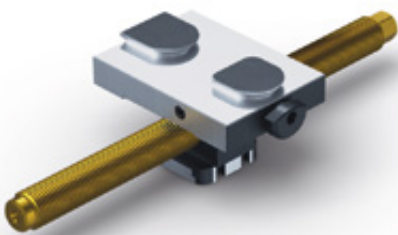

CENTRE BASE JAW + SPINDLE FOR AVANTI 77, JAW WIDTH 77 MM

ITEM NO.	SPINDLE LENGTH (+ \varnothing)	FOR AVANTI	WEIGHT	PRICE
44200-TG77	215 mm ($\varnothing 16$ mm)	44200-77	0.9 kg	

AVANTI 77 ADD-ON JAWS, SOFT



ITEM NO.	MATERIAL	DIMENSIONS	WEIGHT	UNIT	PRICE
44778-36	Steel (16MnCr5)	78 × 58 × 36 mm	0.6 kg	1 pc.	
44779-36	Aluminium (F50)	78 × 58 × 36 mm	0.2 kg	1 pc.	
44778-56	Steel (16MnCr5)	78 × 58 × 56 mm	0.9 kg	1 pc.	
44779-56	Aluminium (F50)	78 × 58 × 56 mm	0.3 kg	1 pc.	

Add-on jaws fit the new base jaw version and also the previous one.