

Avanti 125



AVANTI 125, JAW WIDTH 125 MM

ITEM NO.	BASE LENGTH	MAX. CLAMPING RANGE	WEIGHT	PRICE	COMPARABLE PREVIOUS VERSION
44205-125*	210 mm	210 mm	11.3 kg		44205
44255-125	260 mm	260 mm	13.2 kg		44255
44305-125	310 mm	310 mm	15.1 kg		44305
44355-125	360 mm	360 mm	16.9 kg		44355

*automatable

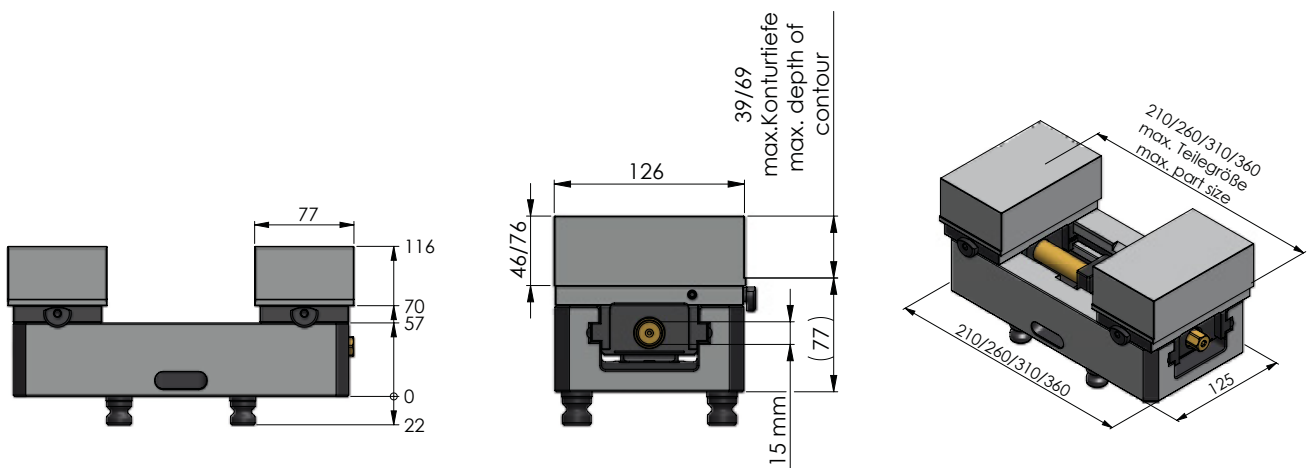



AVANTI 125 BASE JAWS

ITEM NO.	DIMENSIONS	WEIGHT	UNIT	PRICE	COMPARABLE PREVIOUS VERSION
44251-125	125 × 69 mm	3.7 kg	1 pair		44251

NEW

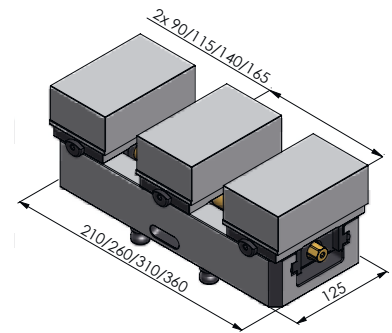
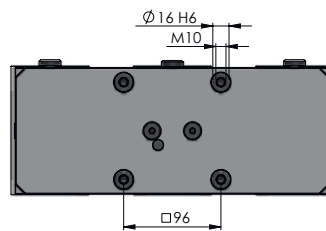
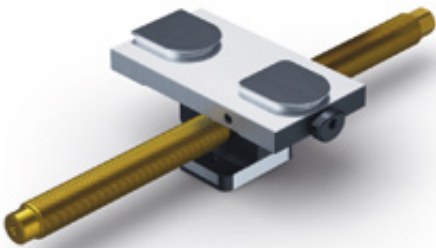

CENTRE BASE JAW + SPINDLE FOR AVANTI 125

ITEM NO.	SPINDLE LENGTH (+Ø)	FOR AVANTI	WEIGHT	PRICE
44255-TG125	264 mm (Ø 20 mm)	44255-125	2.1 kg	
44305-TG125	314 mm (Ø 20 mm)	44305-125	2.2 kg	
44355-TG125	364 mm (Ø 20 mm)	44355-125	2.3 kg	

AVANTI 77 ADD-ON JAWS, SOFT



ITEM NO.	MATERIAL	DIMENSIONS	WEIGHT	UNIT	PRICE
44258-46	Steel (16MnCr5)	126 × 77 × 46 mm	3.3 kg	1 pc.	
44259-46	Aluminium (F50)	126 × 77 × 46 mm	1.1 kg	1 pc.	
44258-76	Steel (16MnCr5)	126 × 77 × 76 mm	5.5 kg	1 pc.	
44259-76	Aluminium (F50)	126 × 77 × 76 mm	1.8 kg	1 pc.	

Add-on jaws fit the new base jaw version and also the previous one.