

Makro·Grip® 5-Axis Vice 125

NEW



MAKRO·GRIP® 5-AXIS VICE 125, JAW WIDTH 77 MM

				
96	Ø 20 mm	max. 100 Nm	max. 20,000 N	± 0.02 mm

ITEM NO.	BASE LENGTH	CLAMPING RANGE	WEIGHT	PRICE
48155-77	160 mm	0 – 155 mm	7.4 kg	
48205-77	210 mm	0 – 205 mm	9.1 kg	

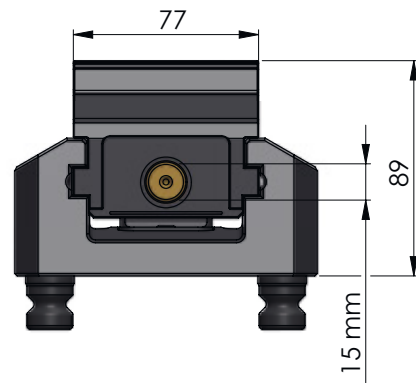
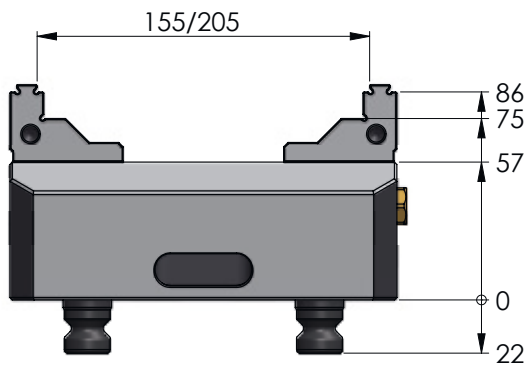
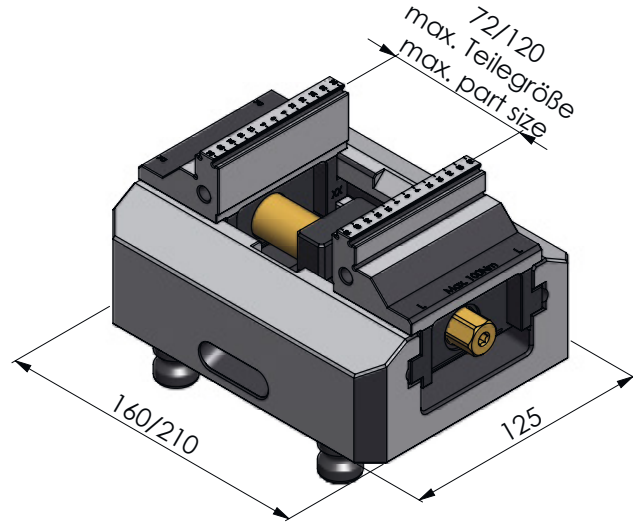
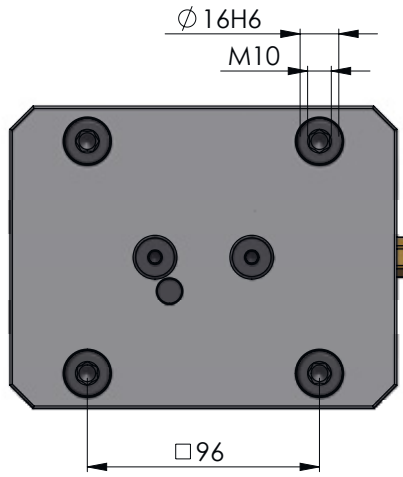

Applications

