

Power Wing Work Gripper PWS06

Inner Diameter Pull Lock Work Gripper PUES06

Suitable for 3 to 5-Axis Machines!

NEW

PWS06



PUES06



Feature 1.

■ **PWS06**

Supply stable clamping by pull back the workpiece.
 Suitable for rough machining, OP-10 or OP-20.

■ **PUES06**

Pull back and clamping the inner diameter of workpiece.
 Suitable for finish machining with stable machining accuracy.

Feature 2.

■ **Built-in cylinder enables the cost reduction !**

No need to introduce separated actuator.

■ **Available on the standard column of machine.**

Total height is reduced by built-in cylinder.

■ **Available to be mounted on NC Rotary Table.**

Specifications

Model	Plunger Stroke mm	Jaw Stroke (diameter) mm	Gripping Force kN(kgf)		Maximum working pressure MPa (kgf/cm ²)		Max. allowable Pressure MPa (kgf/cm ²)	Gripping range mm			Weight (with standard soft jaw) kg	Air consumption (N ₂)
			Pneumatic at 0.6MPa(6kgf/cm ²)	Hydraulic at 1.3MPa(13kgf/cm ²)	Pneumatic	Hydraulic		External diameter	Internal diameter			
PWS06	11.4	7.9	29(2957)	53(5404)	0.7(7)	1.3(13)	0.2(2)	φ12.7-120	φ70-152		24	0.54
Model	Plunger Stroke mm	Jaw Stroke (diameter) mm	Gripping Force kN(kgf)		Maximum working pressure MPa (kgf/cm ²)		Min. allowable Pressure MPa (kgf/cm ²)	Gripping range mm			Weight (with standard soft jaw) kg	Air consumption (N ₂)
PUES06			Pneumatic at 0.6MPa(6kgf/cm ²)	Hydraulic at 1.3MPa(13kgf/cm ²)	Pneumatic	Hydraulic		Master Jaw	Standard Jaw	Option Jaw		
		10	4.8	26.7(2724)	58(5918)	0.7(7)	1.3(13)	0.2(2)	φ44-70	φ70-89	φ89-105	21

Power Wing Work Gripper PWS06

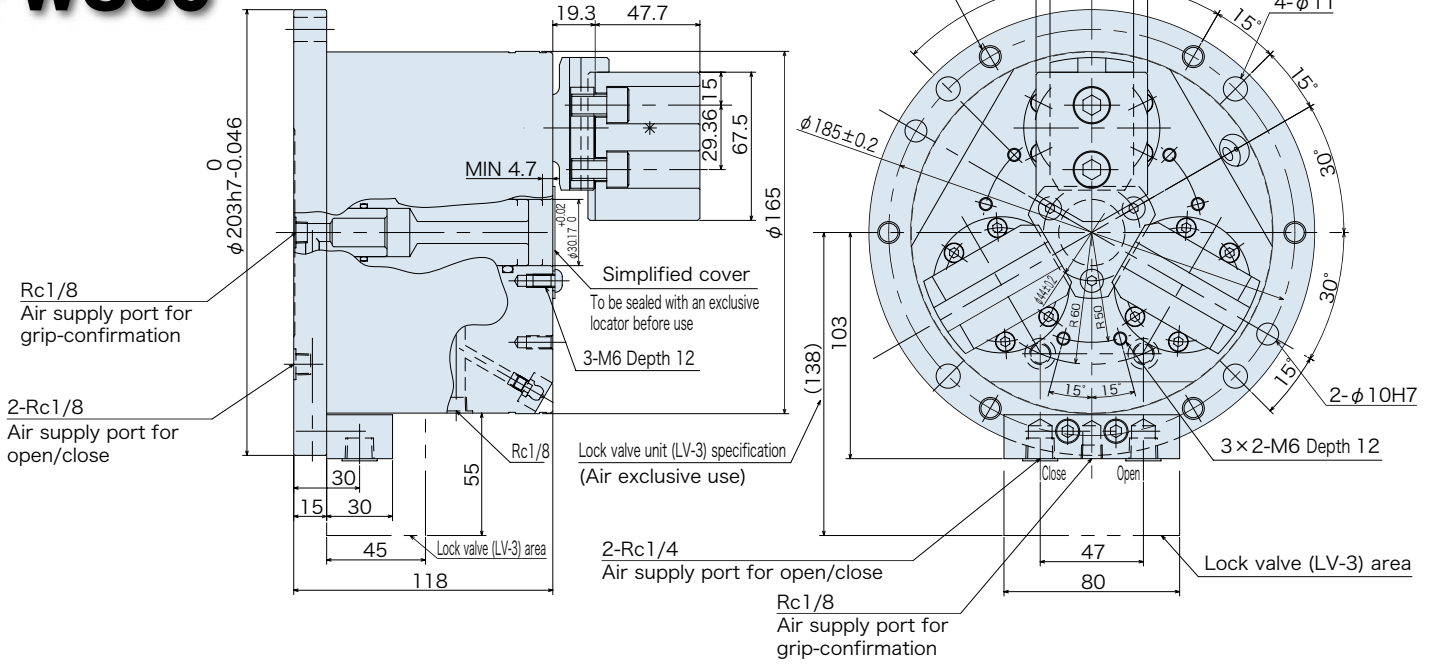

Inner Diameter Pull Lock Work Gripper PUES06

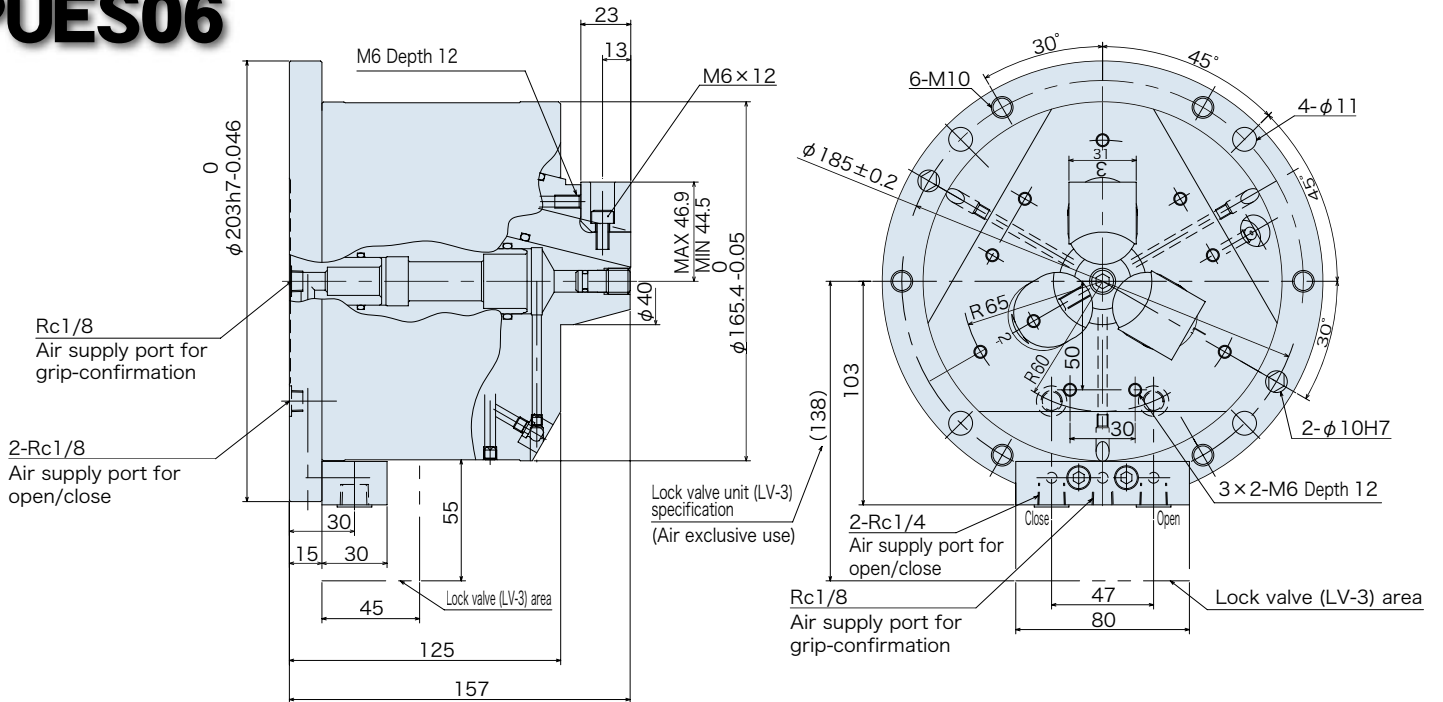

KITAGAWA

Machine Tool Accessories <http://www.mta.kiw.co.jp/>

KITAGAWA IRON WORKS CO., LTD.

77-1 Motomachi, Fuchu-shi, Hiroshima-pref. 726-8610, Japan
TEL +81 847-40-0526 FAX +81 847-45-8911

- Specifications and outside appearance are subject to change without notice due to ongoing research and development.
- The colour of the actual product may be different from the catalogue's due to printing matters.
- Catalogue contents as of 2011.9
- The products herein are controlled under Japanese Foreign Exchange and Foreign Trade Control Act. In the event of importing and/or exporting the products, you are obliged to consult KITAGAWA as well as your government for the related regulation prior to any transaction.