



NC ROTARY TABLE

Multiple Spindle NC Rotary Table

TM series

TM2100·TM3100·TM2160·TM3160
TH2100·TH3100·TH2160·TH3160

Multi spindle range for multiple work piece machining Reduces set up time and increases productivity

- Mono-block body & compact design
- Ideal for tapping machines with high speed rotation
- Working time reduced
- Multi spindle for simultaneous work piece machining



TM

Sample Application

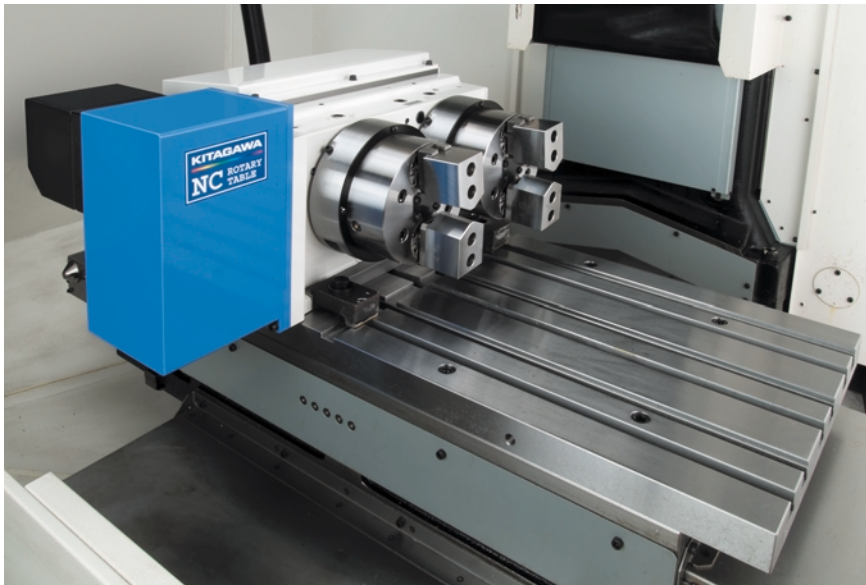

▲Work holding device combining NC Rotary Table and Chuck.

4th axis specifications

※Table Size 100 can be used for only pneumatic type.

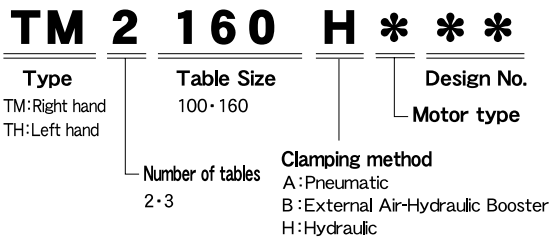





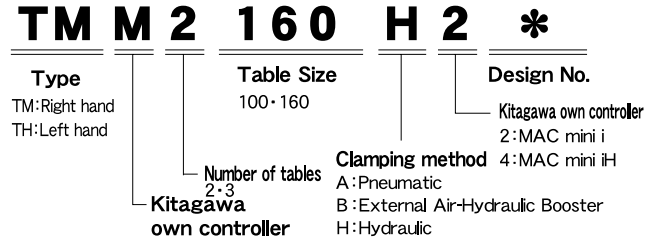

M signal specification

※Table Size 100 can be used for only pneumatic type.



■specification

Model		TM2100	TM3100	TM2160	TM3160
Right hand		○	○	○	○
Left hand		○	○	○	○
Table dia (mm)		φ 105	φ 105	φ 165	φ 165
Register diameter on Face Plate (mm)		φ 50 H7	φ 50 H7	φ 50 H7	φ 50 H7
Spindle through hole diameter (mm)		φ 32	φ 32	φ 40	φ 40
Centre Height (mm)		110	110	140	140
Clamping method		Pneumatic	Pneumatic	Pneumatic/Hydraulic	Pneumatic/Hydraulic
Clamping torque (N·m) (In pneumatic 0.5MPa/hydraulic 3.5MPa)		117	117	176 / 400	176 / 400
Motor axis reduced inertia (kg·m ²)		0.000353	0.000475	0.000145	0.000188
Servomotor (for FANUC specification)		α iF 4/4000	α iF 4/4000	α iF 4/4000	α iF 4/4000
Gear ratio (Decel. Ratio in M signal)		1/36	1/36 (1/60)	1/90	1/90 (1/120)
Max. spindle speed	FANUC specification (for min ⁻¹)	83.3 (for 3000min ⁻¹)	69.4 (for 2500min ⁻¹)	33.3 (for 3000min ⁻¹)	33.3 (for 3000min ⁻¹)
	M signal specification (min ⁻¹)	83.3 (for 3000min ⁻¹)	50 (for 3000min ⁻¹)	33.3 (for 3000min ⁻¹)	16.6 (for 2000min ⁻¹)
Allowable work inertia (kg·m ²)		0.054	0.054	0.51	0.51
Indexing accuracy (sec)		60	60	30	30
Repeatability (sec)		5	5	4	4
Mass of product (kg)		85	100	100	150
Manual Tailstock (as an option)		TS2100	TS3100	TS2160	TS3160
Allowable Load	Horizontal (kg) 	60	60	160	160
	Vertical (kg) 	30	30	80	80
Allowable load	F (kN) 	6	6	10	10
	F _{XL} (N·m) 	200	200	600	600
	F _{XL} (N·m) 	120	120	176 (400)	176 (400)
Allowable cutting torque	T (N·m) 	180	180	300	300

Note) 1. The switch for pressure checking is incorporated to all series except TC/DM of NC tables. 2. In case of air/air-hydraulic clamp specifications, the solenoid valve(s) for table clamp is (are) incorporated. 3. Neither cable nor hose is fitted between NC rotary table and machine tool... 4. Solenoid valve is not incorporated in case of hydraulic clamp method. Consequently, customer shall prepare it. 5. Each product mass is determined by a Kitagawa M signal spec. 6. Contact to Kitagawa about rotary joint and tail spindle.

■ Dimensions [4th axis specifications]

TM2100 (TH)

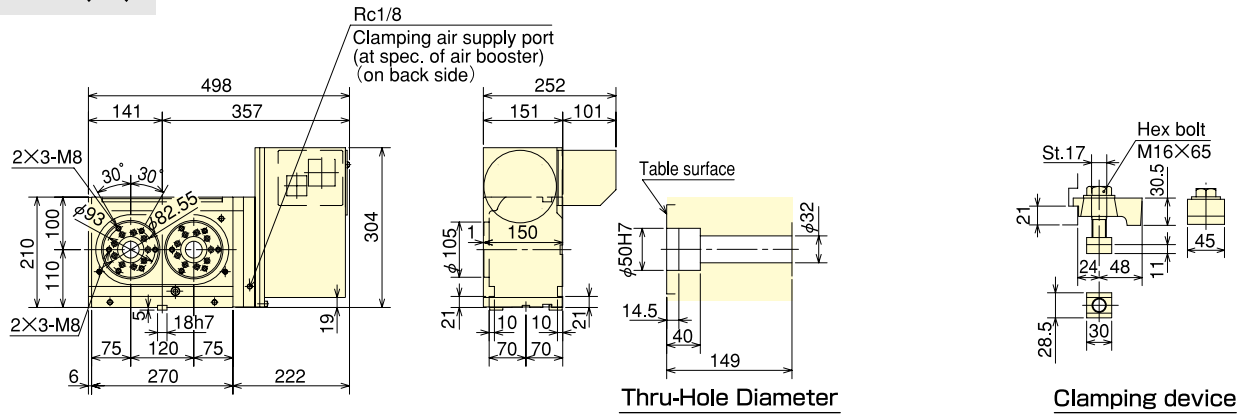

TM3100 (TH)

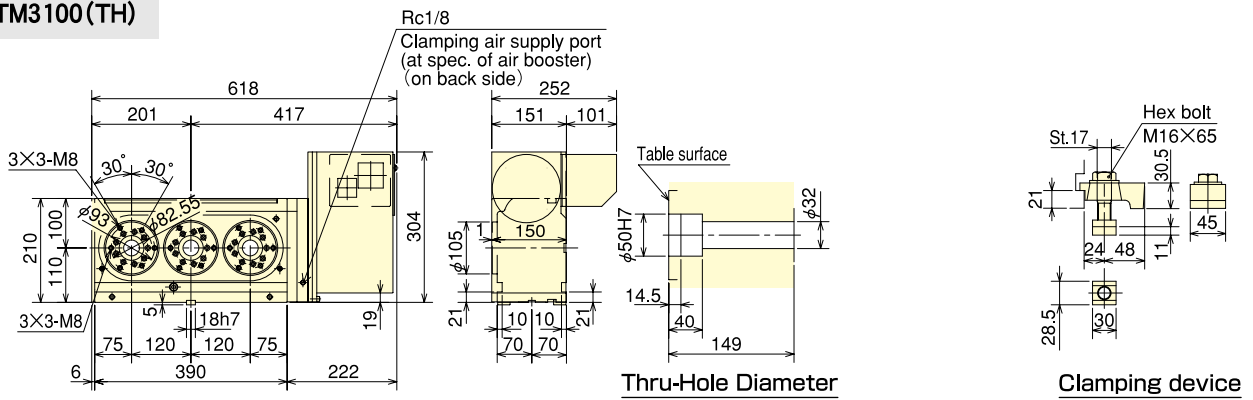

TM2160 (TH)

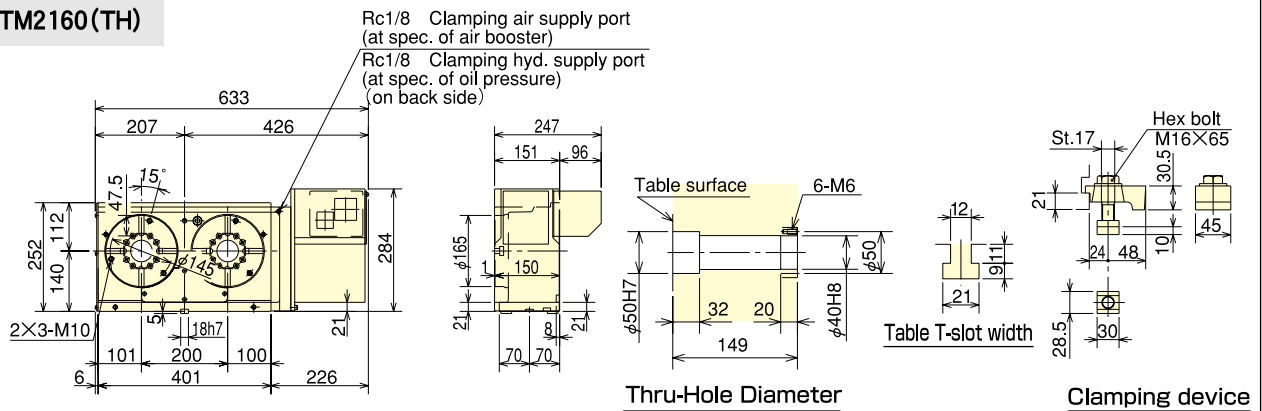

TM3160 (TH)

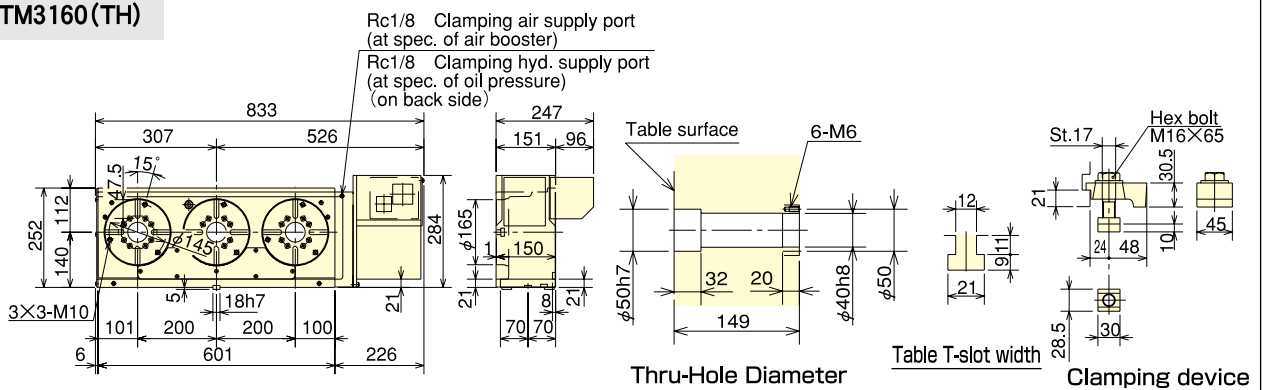

※The above outline dimensions are shown with FANUC motor specifications.
In case of specifications with other makers, the dimensions may differ in length.
TM is used at a right hand and TH is used at a left hand.

■Dimensions [Kitagawa own controller]

TMM2100(THM)

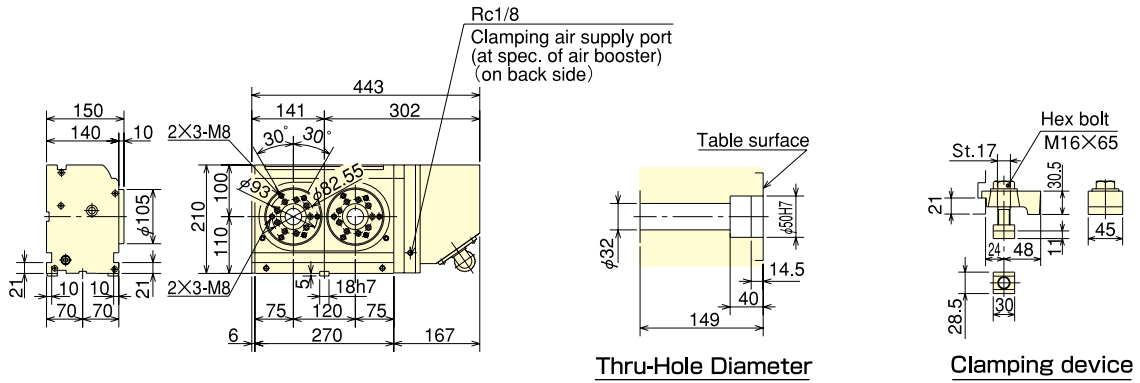

TMM3100(THM)

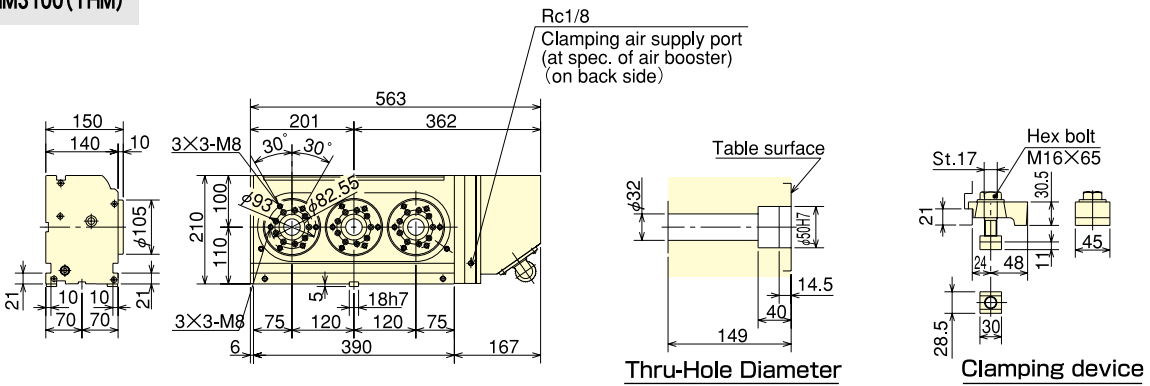

TMM2160(THM)

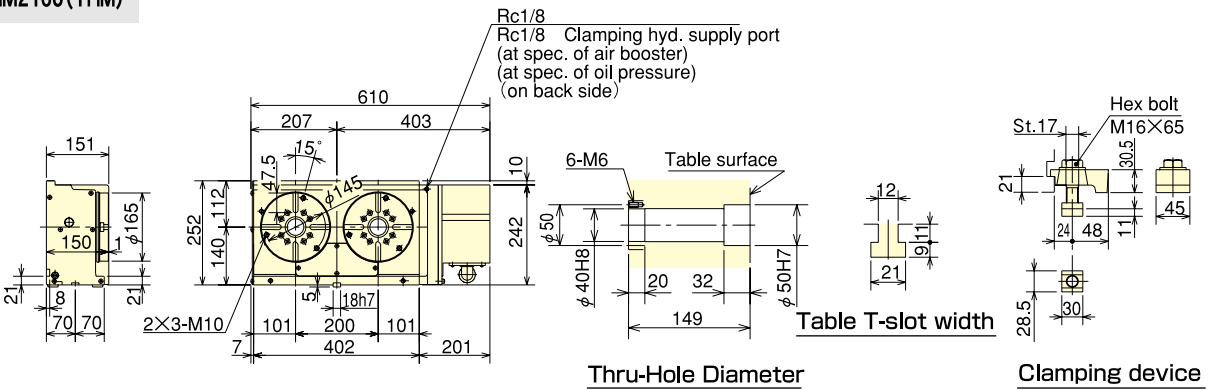

TMM3160(THM)

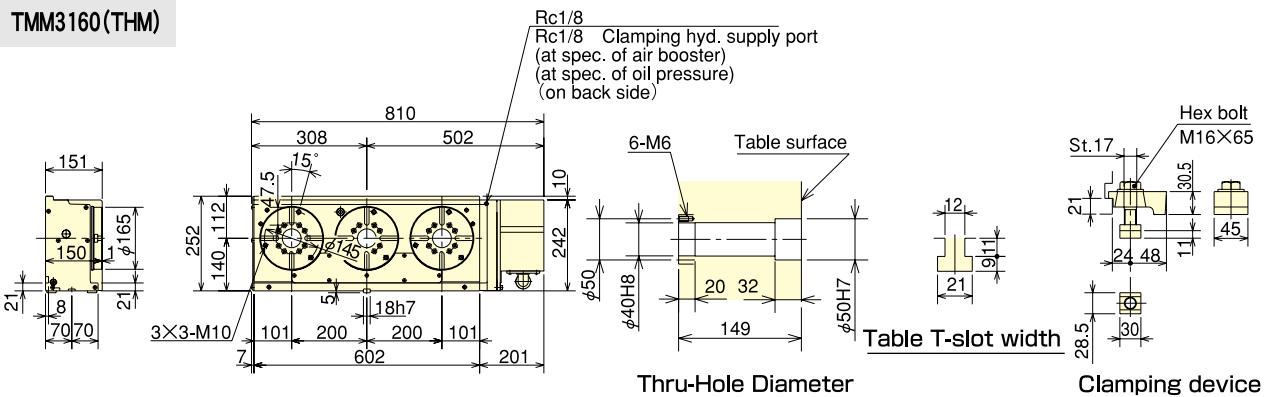

※TM is used at a right hand and TH is used at a left hand.