

NC ROTARY TABLE

High Speed NC Rotary Table RSM100

High Speed Table for Machining Small Work Pieces

- With exclusive controller
- Simple design
- Light weight/compact
- Max. speed 83.3min⁻¹



RSM100

With controller MAC mini iF

Model	RSM100
Right hand	○
Left hand	○
Table dia (mm)	φ 105
Register diameter on Face Plate (mm)	φ 50H7
Spindle through hole diameter (mm)	φ 32
Centre Height (mm)	110
Clamping method	Pneumatic
Clamping torque (N·m) (In pneumatic 0.5MPa)	80
Gear ratio	1/36
Max. spindle speed (for min ⁻¹ /motor 3000min ⁻¹)	83.3
Allowable work inertia (kg·m ²)	0.054
Indexing accuracy (sec)	50
Repeatability (sec)	10
Mass of product (kg)	23
Manual Tailstock (as an option · P69 reference)	RS100RN

Model	RSM100	
Allowable Load	Horizontal (kg)	60
	Vertical (kg)	30
Allowable load	F (kN)	6
	FXL (N·m)	200
	FXL (N·m)	82
Allowable cutting torque	T (N·m)	40

※RSM100 : With MAC mini i(H)F

Note) This model is for only M signal spec., and it is not provided for 4th axis specification.

Dimensions

RSM100R(L) [Kitagawa own controller]

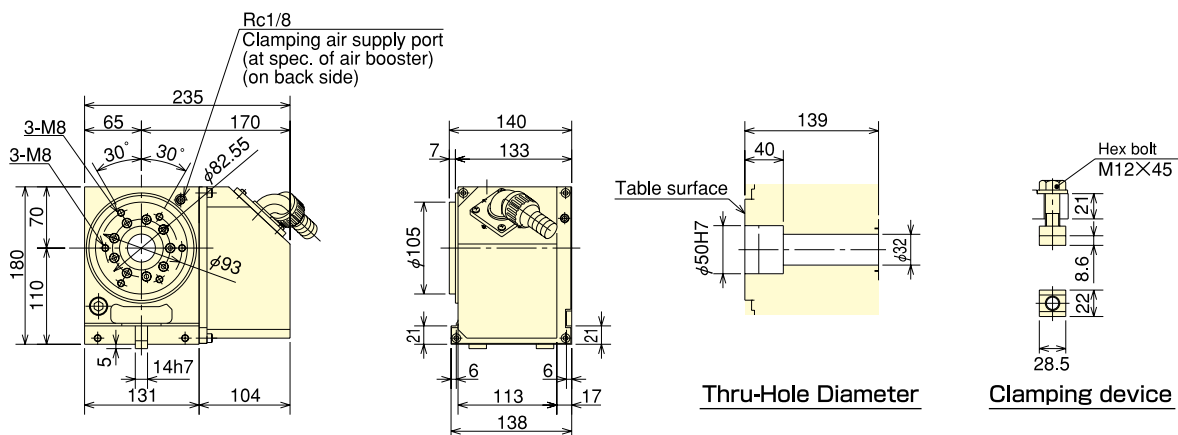

※The notation "R" means right handed ; "L" means left handed model.