

VISE

Power Vises for Center Groove Tables VE125N-15 · VQX125N-15

**Problem with key grooves...??
Use the center guide block vises!**

- Guide block just fit to center groove tables
- Stable clamping force ensured by the mechanical-type enhancement toggle mechanism
- Lift-up reduced to the minimum, offering stable machining accuracy
- Standard parallel specification

Suitable for long-size work and simultaneous machining of multiple workpieces

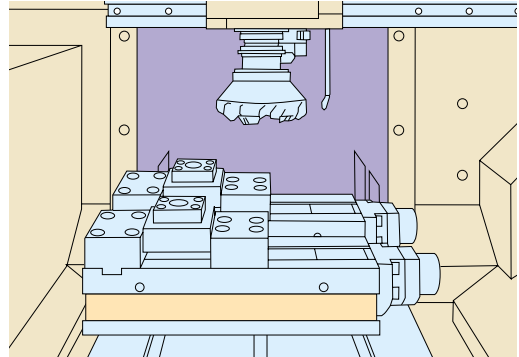

Dimensions

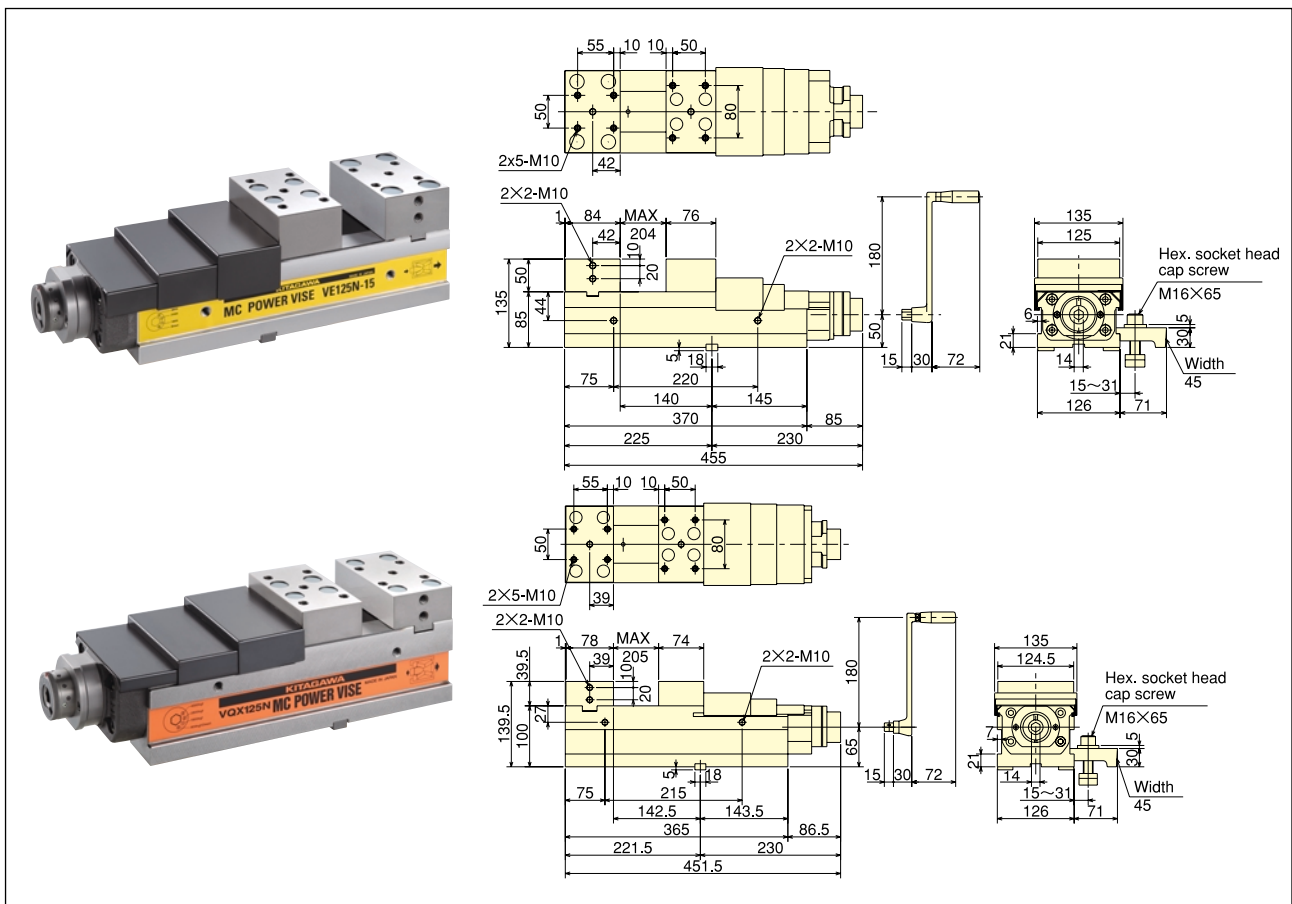

Clamping Force Table (Unit : kN)

Range	3	2	1	0
VE125N-15	30	21	12	8
VQX125N-15	40	28	16	8

※Zero range means clamp without a step-up mechanism.
Clamp force shows an allowable amount.

Specifications

(Unit : mm)

Model	Jaw width	Jaw height	Jaw stroke	Total height	Work mounting face height	Full width	Full length	Max. clamping force(kN)	Mass (kg)
VE125N-15	125	50	204	135	85	135	455	30	35
VQX125N-15	124.5	40	205	140	100	135	451.5	40	35

■ **Body Material** : VE125N-15 steel, VQX125N-15 cast iron ■ **Jaw Material** : Hardened steel

■ **Standard Accessories** : Clamp device assembly (clamp device, T-nut(s), bolt(s), washer(s)), handle, L-shaped hexagonal wrench, C-caps, slide cover

■ **Options** : Parallel clamp device, stepped guide block, ratchet handle, extension bar, soft jaws (a set of a moving-side and a fixed-side jaws)

※The guide block can be changed to suit the machine where the vise is mounted. In this case, please contact us.