

Quick Change Series Power Collet Chuck for Bar Machining

Bar Seals Prevent Swarf & Coolant Ingress



Remove bar seal from housing



Mark the diameter you require



Cut out the diameter



Reassemble and proceed

Adjustable Collet Mounted Workstop for Spring Collets



- Easy to use, installation time – less than one minute
- Available for D173E (Part No: **WS-D173E**) and D185E (Part No: **WS-D185E**) spring collet types
- Suitable for round, square and hexagon spring collets
- No deformation of collet shank
- No influence on clamping characteristics of collet or collet chuck



Insert collet work stopper



Lock stopper housing in position



Adjust stopper shaft position



Lock stopper shaft and install

Application Advantages

- Klamp collet chucks are designed to work with bar loaders and bar feeders by not interfering with the actions of the bar feeder or loader.
- All types of QCRL42, QCRL60 & QCRL80 have interchangeable match ground reduction sleeves to allow you to use a wider range of collets on one chuck.
- Wide adaptor plates for all models available upon request.
- Clamping/unclamping of chuck during spindle rotation is possible.
- Less deformation of thin-walled components during clamping.
- High operating reliability due to a minimum number of parts.
- High axial positioning accuracy of the components by means of push type collet system.

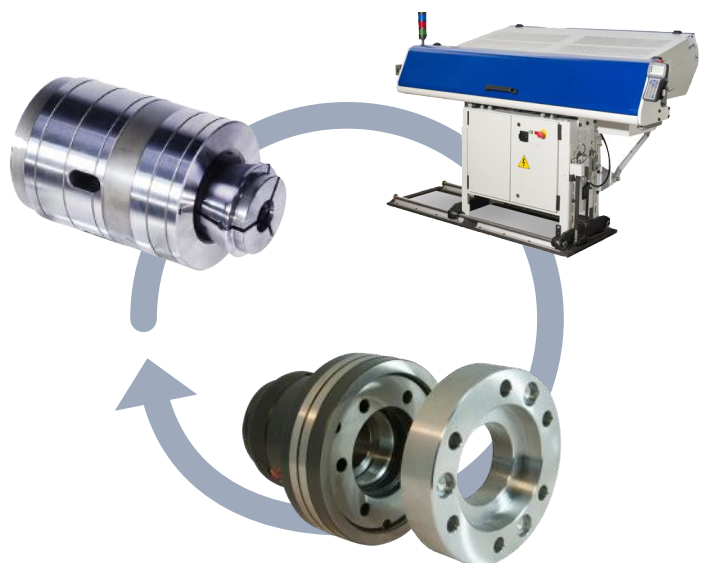

* See pages 14-18 for more Spring Collet information.

** See pages 22-23 for more Varibore Collet information.

*** DRFC673 Rubber-flex collets are only suitable for the CRL42 Collet chuck and are available in smooth and full grip versions (smooth version is only available for 11mm diameters and smaller). DRFC677 Rubber-flex collets are only suitable for the CRL60 Collet chuck and are available in smooth and full grip versions (smooth version is only available for 61mm diameters and larger). See pages 24-25 for more information.

Quick Change Series Power Collet Chuck for Bar Machining

Two Different Systems:

Direct Mount System

- This system mounts directly to the lathe spindle to ensure a consistent mounting without the need for correction.
- Klamp QDCRL collet chucks are suitable for spring, varibore and rubberflex collets increasing its flexibility. Varibore and rubberflex collets allow rough, unfinished bar to be machined in the first operation and spring collets can be used for high accuracy in the second operation.
- Workpiece remains in a fixed position during actuation allowing for precise z-axis positioning. A tapered sleeve is pushed forward, compressing the collet and gripping the workpiece.
- All Klamp collet chucks are case hardened, optimising the rigidity, strength and durability.



Modular System

- As the direct mount system except with interchangeable adaptors enables the collet chuck to be moved from one machine spindle nose to another
- Cost-effective as only additional adaptors and connectors are required when changing different spindle/machine.
- The need for adjustment is minimal, meaning less machine downtime.



Ultra-Fast 10 Second Collet Changes



3 Different Collet Types Available



Spring Collets*

Suited for second operation work, collets are size matched according to gripped diameters, enabling you to have a high gripping accuracy. Collets can be supplied as smooth or serrated as required.



Varibore Collets**

Ideal for first operation work as they have a 2-3mm gripping range enabling you to handle rough bar. Supplied either as smooth, serrated or super grip.

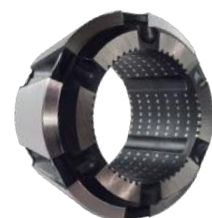

Rubberflex Collets***

The same accuracy specification as spring collets. Elastic rubber-metal vulcanization allows a clamping range of +/- 1mm to the nominal diameter.

Quick Change Series Power Collet Chuck for Bar Machining

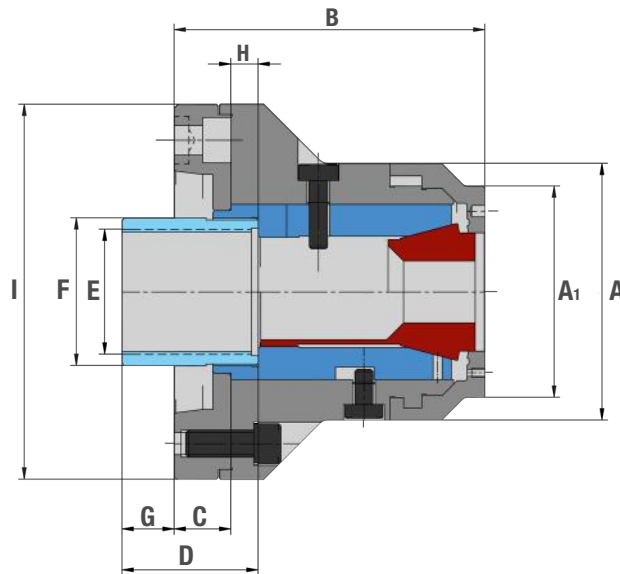

KLAMP Type	Q-CRL42 DIN			Q-CRL54 Inch				Q-CRL60 DIN				
	Z140	A5	A6	Z170	A5	A6	A8	Z170	A5	A6	A8	
Part Number	QCRL42	QCRL42A5	QCRL42A6	QCRL54	QCRL54A5	QCRL54A6	QCRL54A8	QCRL60	QCRL60A5	QCRL60A6	QCRL60A8	
Spring Collet Type	D173E			D853				D185E				
Spring Collet Gripping Range	Minimum	2			1.6				3			
	Maximum	42			54				60			
Spring collet increments	0.5			0.5				0.5				
Varibore Collet Type	D673			D-120				D-677				
Varibore Collet Gripping Range	Minimum	4			3				4			
	Maximum	42			53.9				60			
Varibore Collet Increments	2			3				2				
Rubberflex Collet Type	DRFC673			-				DRFC677				
Rubberflex Collet Gripping Range	Minimum	7			-				19*			
	Maximum	45			-				65*			
Rubberflex Collet Increments	2			-				2				
A	113			143				143				
A1	93			118				118				
B	137			175	184	169	169	171	180	165	165	
C	25			31.5	46.5	31.5	31.5	31.5	46.5	31.5	31.5	
D	60			60				60				
E Maximum	M58 x 1.5			M75 x 1.5				M75 x 1.5				
F	65			82				82				
G Maximum	17	23	23	15	25	21	21	14	-22	21	21	
G Minimum	10	16	16	5	15	11	11	7	-15	14	14	
H	12			8.3				8.3				
I	165			220				220				
Sleeve stroke	7			10				7				
Max. input force	kN	25			30				30			
Max. Gripping Force	kN	55			60				60			
Max. Speed	min ⁻¹	7100			6300				6300			
Net Weight	kg	14.5	14	13.5	28.3	32	28.3	26.3	28.3	32	28.3	26.3
Matching Kitagawa Cylinders	S1246 SS1246			S1552 S1875				S1552 S1875				

Spring Collets for CRL54 and QCRL54 Collet Chucks

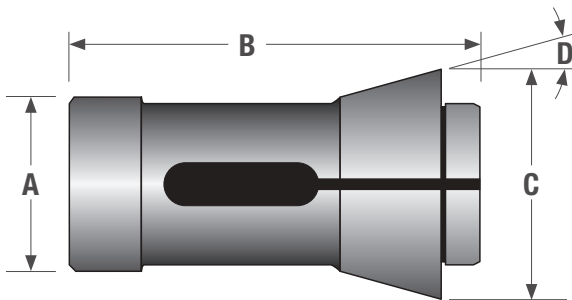

D853 Spring Collets

- Type: 1503
- Round standard shape only
- Specify which gripping surface you require Annular serrations or smooth
- 0.5mm sizes and other shapes available upon request

Dimensions (Metric)

A	B	C	D
60.28	125.4	88.1	15° 15'

Gripping Diameter	Round	Gripping Diameter	Round
2mm	D853E R02	29mm	D853E R29
3mm	D853E R03	30mm	D853E R30
4mm	D853E R04	31mm	D853E R31
5mm	D853E R05	32mm	D853E R32
6mm	D853E R06	33mm	D853E R33
7mm	D853E R07	34mm	D853E R34
8mm	D853E R08	35mm	D853E R35
9mm	D853E R09	36mm	D853E R36
10mm	D853E R10	37mm	D853E R37
11mm	D853E R11	38mm	D853E R38
12mm	D853E R12	39mm	D853E R39
13mm	D853E R13	40mm	D853E R40
14mm	D853E R14	41mm	D853E R41
15mm	D853E R15	42mm	D853E R42
16mm	D853E R16	43mm	D853E R43
17mm	D853E R17	44mm	D853E R44
18mm	D853E R18	45mm	D853E R45
19mm	D853E R19	46mm	D853E R46
20mm	D853E R20	47mm	D853E R47
21mm	D853E R21	48mm	D853E R48
22mm	D853E R22	49mm	D853E R49
23mm	D853E R23	50mm	D853E R50
24mm	D853E R24	51mm	D853E R51
25mm	D853E R25	52mm	D853E R52
26mm	D853E R26	53mm	D853E R53
27mm	D853E R27	54mm	D853E R54
28mm	D853E R28		

Emergency Collet with soft face and pilot hole 6mm dia. is available - Part No. **D853-EMERGENCY**

Varibore Collets for CRS54, QCRL54, CRS66, QCRS66, QCRL66 & QCRS80 Collet Chucks

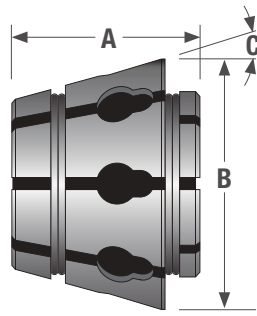

Varibore Collets

- Round, Hexagon or Square
- Specify which gripping surface you require – Supergrip Serrations (Heavy duty), Annular Serrations or Smooth
- Other shapes available upon request

Dimensions (Metric)

Part No.	A	B	C
D120	62.7	88	15°
D285	73.2	99.3	15°
D175	80	120	15°

Gripping Range		D120 for CRS54 & QCRL54			D285 for CRS66, QCRS66 & QCRL66			D175 for QCRS80		
Inch	mm	Round	Hexagon	Square	Round	Hexagon	Square	Round	Hexagon	Square
1/16 - 3/16	1.58 - 4.76	D120R-D01	-	-	-	-	-	-	-	-
1/8 - 1/4	3.17 - 6.35	D120R-D02	D120X-D69	D120S-D87	D285R-E02	D285X-E69	D285S-E87	-	-	-
1/4 - 3/8	6.35 - 9.52	D120R-D03	D120X-D70	D120S-D88	D285R-E03	D285X-E70	D285S-E88	-	-	-
3/8 - 1/2	9.52 - 12.70	D120R-D04	D120X-D71	D120S-D89	D285R-E04	D285X-E71	D285S-E89	-	-	-
1/2 - 5/8	12.70 - 15.87	D120R-D05	D120X-D72	D120S-D90	D285R-E05	D285X-E72	D285S-E90	D175R-F05	D175X-F72	D175S-F100
5/8 - 3/4	15.87 - 19.05	D120R-D06	D120X-D73	D120S-D91	D285R-E06	D285X-E73	D285S-E91	D175R-F06	D175X-F73	D175S-F101
3/4 - 7/8	19.05 - 22.22	D120R-D07	D120X-D74	D120S-D92	D285R-E07	D285X-E74	D285S-E92	D175R-F07	D175X-F74	D175S-F102
7/8 - 1	22.22 - 25.40	D120R-D08	D120X-D75	D120S-D93	D285R-E08	D285X-E75	D285S-E93	D175R-F08	D175X-F75	D175S-F103
1 - 1.1/8	25.40 - 28.57	D120R-D09	D120X-D76	D120S-D94	D285R-E09	D285X-E76	D285S-E94	D175R-F09	D175X-F76	D175S-F104
1.1/8 - 1.1/4	28.57 - 31.75	D120R-D10	D120X-D77	D120S-D95	D285R-E10	D285X-E77	D285S-E95	D175R-F10	D175X-F77	D175S-F105
1.1/4 - 1.3/8	31.75 - 34.92	D120R-D11	D120X-D78	D120S-D96	D285R-E11	D285X-E78	D285S-E96	D175R-F11	D175X-F78	D175S-F106
1.3/8 - 1.1/2	34.92 - 38.10	D120R-D12	D120X-D79	D120S-D97	D285R-E12	D285X-E79	D285S-E97	D175R-F12	D175X-F79	D175S-F107
1.1/2 - 1.5/8	38.10 - 41.27	D120R-D13	D120X-D80	D120S-D98	D285R-E13	D285X-E80	D285S-E98	D175R-F13	D175X-F80	D175S-F108
1.5/8 - 1.3/4	41.27 - 44.45	D120R-D14	D120X-D81	-	D285R-E14	D285X-E81	D285S-E99	D175R-F14	D175X-F81	D175S-F109
1.3/4 - 1.7/8	44.45 - 47.62	D120R-D15	D120X-D82	-	D285R-E15	D285X-E82	-	D175R-F15	D175X-F82	D175S-F110
1.7/8 - 2	47.62 - 50.80	D120R-D16	D120X-D83	-	D285R-E16	D285X-E83	-	D175R-F16	D175X-F83	D175S-F111
2 - 2.1/8	50.80 - 53.97	D120R-D17	-	-	D285R-E17	D285X-E84	-	D175R-F17	D175X-F84	D175S-F112
2.1/8 - 2.1/4	53.97 - 57.15	-	-	-	D285R-E18	D285X-E85	-	D175R-F18	D175X-F85	-
2.1/4 - 2.3/8	57.15 - 60.32	-	-	-	D285R-E19	-	-	D175R-F19	D175X-F86	-
2.3/8 - 2.1/2	60.32 - 63.50	-	-	-	D285R-E20	-	-	D175R-F20	D175X-F87	-
2.1/2 - 2.5/8	63.50 - 66.67	-	-	-	D285R-E21	-	-	D175R-F21	D175X-F88	-
2.5/8 - 2.3/4	66.67 - 69.85	-	-	-	-	-	-	D175R-F22	-	-
2.3/4 - 2.7/8	69.85 - 73.02	-	-	-	-	-	-	D175R-F23	-	-
2.7/8 - 3	73.02 - 76.20	-	-	-	-	-	-	D175R-F24	-	-
3 - 3.1/8	76.20 - 79.37	-	-	-	-	-	-	D175R-F25	-	-

Emergency Collets with soft face and pilot hole is available for all types

QC & C Series Standard Accessories

Work Stops

- Stops can be provided to allow for accurate z-axis positioning of short workpieces within the collet chuck.
- A threaded stud is provided for easy adjustment to suit your work piece
- All stops are easily installed from the front face utilising a side bolt to hold the stop securely in place.
- These stops can be installed on all QC & C series collet chucks.
- Full length spindle stops can also be provided for long work pieces, these can utilise the entire length of your machine spindle, please contact your Klamp supplier to see the maximum length stop your machine could accommodate.

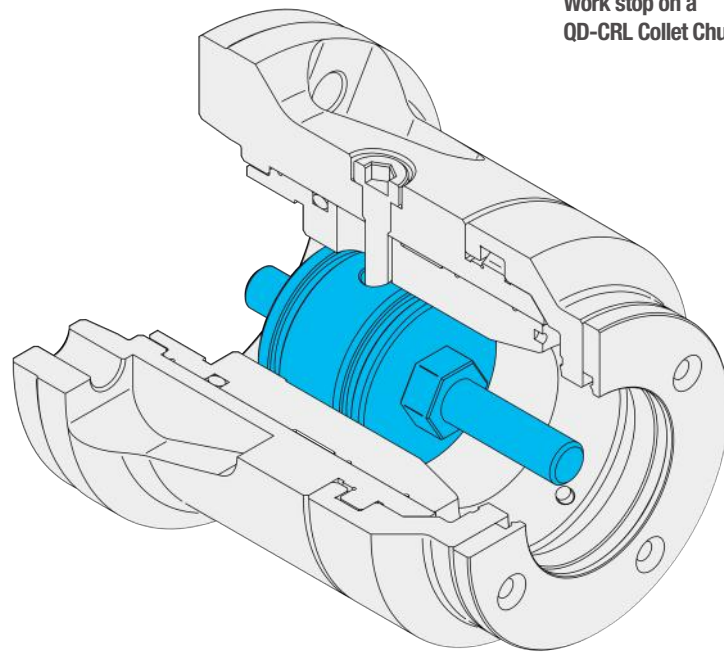

Work stop on a QD-CRL Collet Chuck

Spring Ejectors

- Standard spring ejectors for QC & C series are used for second-spindle operations to expel finished workpieces into the parts catcher.
- Many variants of spring ejector are available to suit your production process.
- Spring ejectors can be installed on all QC & C series collet chucks.
- Full length hydraulic or pneumatic ejectors can also be provided for long work pieces, this can utilise the entire length of your machine spindle, please contact your Klamp supplier to see the maximum length stop your machine could accommodate.

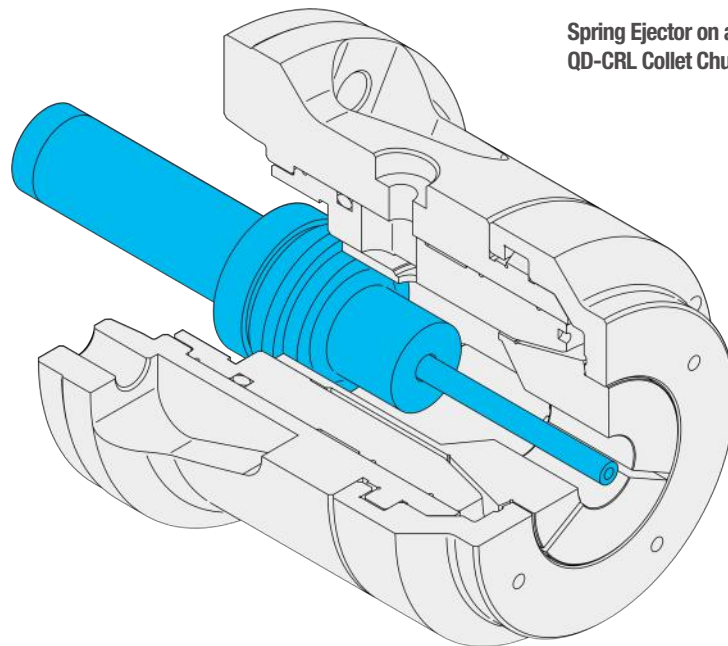

Spring Ejector on a QD-CRL Collet Chuck