

Quick Change Series Power Collet Chuck for Bar Machining

Bar Seals Prevent Swarf & Coolant Ingress

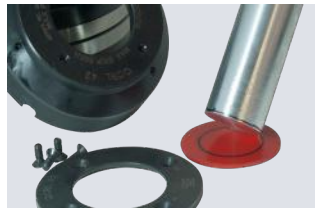

Remove bar seal from housing



Mark the diameter you require



Cut out the diameter



Reassemble and proceed

Adjustable Collet Mounted Workstop for Spring Collets



- Easy to use, installation time – less than one minute
- Available for D173E (Part No: **WS-D173E**) and D185E (Part No: **WS-D185E**) spring collet types
- Suitable for round, square and hexagon spring collets
- No deformation of collet shank
- No influence on clamping characteristics of collet or collet chuck



Insert collet work stopper



Lock stopper housing in position



Adjust stopper shaft position



Lock stopper shaft and install

Application Advantages

- Klamp collet chucks are designed to work with bar loaders and bar feeders by not interfering with the actions of the bar feeder or loader.
- All types of QCRL42, QCRL60 & QCRL80 have interchangeable match ground reduction sleeves to allow you to use a wider range of collets on one chuck.
- Wide adaptor plates for all models available upon request.
- Clamping/unclamping of chuck during spindle rotation is possible.
- Less deformation of thin-walled components during clamping.
- High operating reliability due to a minimum number of parts.
- High axial positioning accuracy of the components by means of push type collet system.

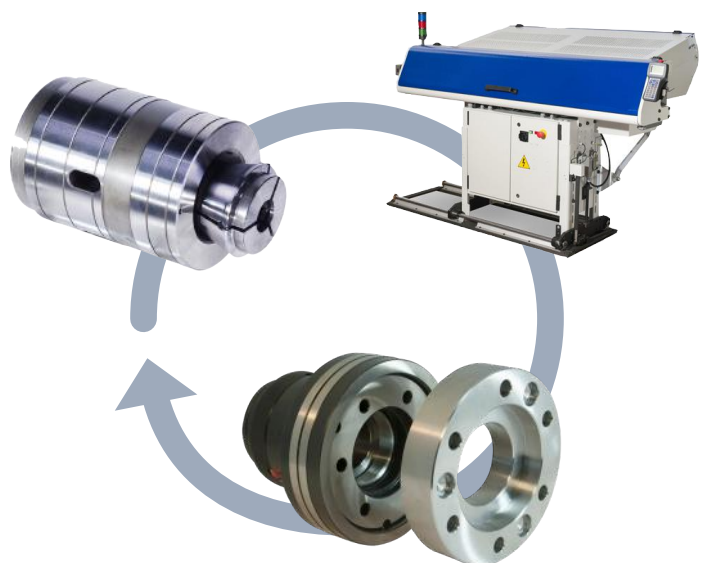

* See pages 14-18 for more Spring Collet information.

** See pages 22-23 for more Varibore Collet information.

*** DRFC673 Rubber-flex collets are only suitable for the CRL42 Collet chuck and are available in smooth and full grip versions (smooth version is only available for 11mm diameters and smaller). DRFC677 Rubber-flex collets are only suitable for the CRL60 Collet chuck and are available in smooth and full grip versions (smooth version is only available for 61mm diameters and larger). See pages 24-25 for more information.

Quick Change Series Power Collet Chuck for Bar Machining

Two Different Systems:

Direct Mount System

- This system mounts directly to the lathe spindle to ensure a consistent mounting without the need for correction.
- Klamp QDCRL collet chucks are suitable for spring, varibore and rubberflex collets increasing its flexibility. Varibore and rubberflex collets allow rough, unfinished bar to be machined in the first operation and spring collets can be used for high accuracy in the second operation.
- Workpiece remains in a fixed position during actuation allowing for precise z-axis positioning. A tapered sleeve is pushed forward, compressing the collet and gripping the workpiece.
- All Klamp collet chucks are case hardened, optimising the rigidity, strength and durability.



Modular System

- As the direct mount system except with interchangeable adaptors enables the collet chuck to be moved from one machine spindle nose to another
- Cost-effective as only additional adaptors and connectors are required when changing different spindle/machine.
- The need for adjustment is minimal, meaning less machine downtime.



Ultra-Fast 10 Second Collet Changes



3 Different Collet Types Available



Spring Collets*

Suited for second operation work, collets are size matched according to gripped diameters, enabling you to have a high gripping accuracy. Collets can be supplied as smooth or serrated as required.



Varibore Collets**

Ideal for first operation work as they have a 2-3mm gripping range enabling you to handle rough bar. Supplied either as smooth, serrated or super grip.

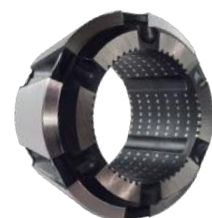

Rubberflex Collets***

The same accuracy specification as spring collets. Elastic rubber-metal vulcanization allows a clamping range of +/- 1mm to the nominal diameter.

Quick Change Series Power Collet Chuck for Bar Machining

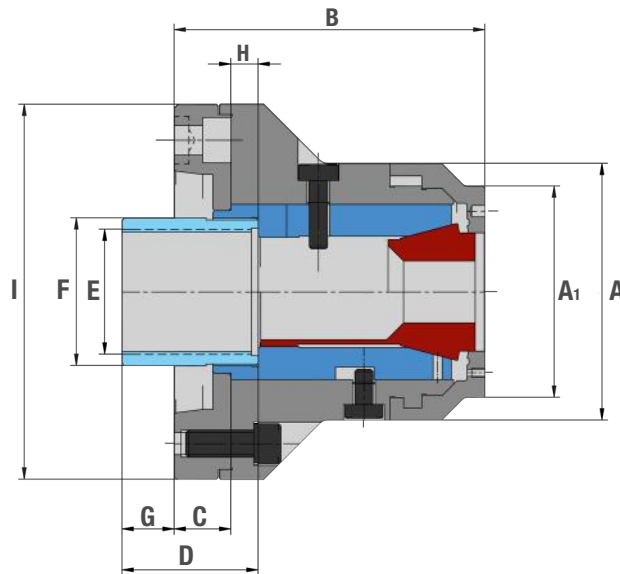

KLAMP Type	Q-CRL42 DIN			Q-CRL54 Inch				Q-CRL60 DIN				
	Z140	A5	A6	Z170	A5	A6	A8	Z170	A5	A6	A8	
Part Number	QCRL42	QCRL42A5	QCRL42A6	QCRL54	QCRL54A5	QCRL54A6	QCRL54A8	QCRL60	QCRL60A5	QCRL60A6	QCRL60A8	
Spring Collet Type	D173E			D853				D185E				
Spring Collet Gripping Range	Minimum	2			1.6				3			
	Maximum	42			54				60			
Spring collet increments	0.5			0.5				0.5				
Varibore Collet Type	D673			D-120				D-677				
Varibore Collet Gripping Range	Minimum	4			3				4			
	Maximum	42			53.9				60			
Varibore Collet Increments	2			3				2				
Rubberflex Collet Type	DRFC673			-				DRFC677				
Rubberflex Collet Gripping Range	Minimum	7			-				19*			
	Maximum	45			-				65*			
Rubberflex Collet Increments	2			-				2				
A	113			143				143				
A1	93			118				118				
B	137			175	184	169	169	171	180	165	165	
C	25			31.5	46.5	31.5	31.5	31.5	46.5	31.5	31.5	
D	60			60				60				
E Maximum	M58 x 1.5			M75 x 1.5				M75 x 1.5				
F	65			82				82				
G Maximum	17	23	23	15	25	21	21	14	-22	21	21	
G Minimum	10	16	16	5	15	11	11	7	-15	14	14	
H	12			8.3				8.3				
I	165			220				220				
Sleeve stroke	7			10				7				
Max. input force	kN	25			30				30			
Max. Gripping Force	kN	55			60				60			
Max. Speed	min ⁻¹	7100			6300				6300			
Net Weight	kg	14.5	14	13.5	28.3	32	28.3	26.3	28.3	32	28.3	26.3
Matching Kitagawa Cylinders	S1246 SS1246			S1552 S1875				S1552 S1875				

Spring collets for CRL60 and QCRL60 Collet Chucks

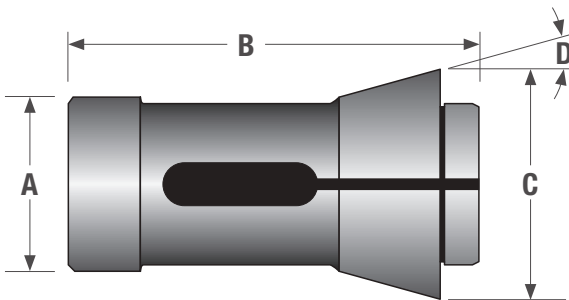

D185E Spring Collets

- DIN 6343 Type: 4291 (Also known as B60)
- Round, Hexagon or Square
- Specify which gripping surface you require Annular serrations or smooth
- 0.5mm sizes and other shapes available upon request

Dimensions (Metric)

A	B	C	D
66	110	84	15°

Gripping Diameter	Round	Hexagon	Square
3mm	D185E R03	-	-
4mm	D185E R04	-	-
5mm	D185E R05	D185E X05	D185E S05
6mm	D185E R06	-	D185E S06
7mm	D185E R07	D185E X07	D185E S07
8mm	D185E R08	D185E X08	D185E S08
9mm	D185E R09	-	-
10mm	D185E R10	D185E X10	D185E S10
11mm	D185E R11	D185E X11	-
12mm	D185E R12	D185E X12	D185E S12
13mm	D185E R13	D185E X13	-
14mm	D185E R14	D185E X14	D185E S14
15mm	D185E R15	D185E X15	D185E S15
16mm	D185E R16	D185E X16	D185E S16
17mm	D185E R17	D185E X17	-
18mm	D185E R18	D185E X18	D185E S18
19mm	D185E R19	D185E X19	-
20mm	D185E R20	D185E X20	D185E S20
21mm	D185E R21	-	-
22mm	D185E R22	D185E X22	D185E S22
23mm	D185E R23	-	-
24mm	D185E R24	D185E X24	-
25mm	D185E R25	D185E X25	D185E S25
26mm	D185E R26	D185E X26	-
27mm	D185E R27	D185E X27	-
28mm	D185E R28	-	-
29mm	D185E R29	-	-
30mm	D185E R30	D185E X30	D185E S30
31mm	D185E R31	-	-

Gripping Diameter	Round	Hexagon	Square
32mm	D185E R32	D185E X32	D185E S32
33mm	D185E R33	-	-
34mm	D185E R34	-	-
35mm	D185E R35	D185E X35	D185E S35
36mm	D185E R36	D185E X36	D185E S36
37mm	D185E R37	-	-
38mm	D185E R38	-	-
39mm	D185E R39	-	-
40mm	D185E R40	-	D185E S40
41mm	D185E R41	D185E X41	-
42mm	D185E R42	-	-
43mm	D185E R43	-	-
44mm	D185E R44	-	-
45mm	D185E R45	-	-
46mm	D185E R46	-	-
47mm	D185E R47	-	-
48mm	D185E R48	-	-
49mm	D185E R49	-	-
50mm	D185E R50	D185E X50	-
51mm	D185E R51	-	-
52mm	D185E R52	-	-
53mm	D185E R53	-	-
54mm	D185E R54	-	-
55mm	D185E R55	-	-
56mm	D185E R56	-	-
57mm	D185E R57	-	-
58mm	D185E R58	-	-
59mm	D185E R59	-	-
60mm	D185E R60	-	-

Emergency Collet with soft face and pilot hole 4mm diameter is available - Part No. **D185E-EMERGENCY**

Rubber-Flex Collets for CRL42, QCRL42, CRS60, CRL60, QCRL60 Collet Chucks

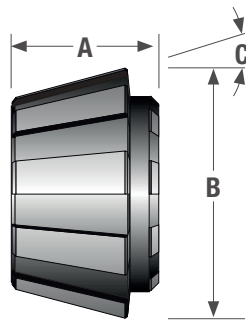
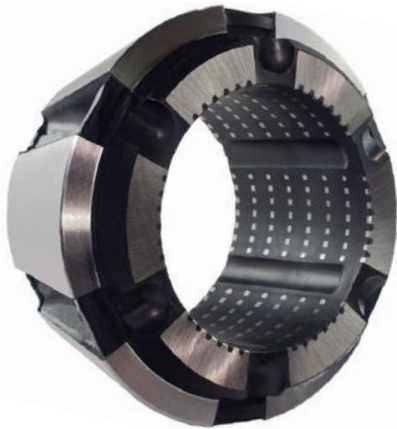

Rubberflex Collets – Type: DIN 6343

- Round, Hexagon or Square
- Specify which gripping surface you require – Full Grip or Smooth
Smooth Type – **DRFCXXX-RXX**
Full Grip Type – **DRFCXXX-RXX/R**

Dimensions (Metric)

Part No.	A	B	C
DRFC673	39	61.5	14.75°
DRFC677	45	85.5	14.75°

Gripping Range mm	DRFC673 DIN for CRL42 & QCRL42	DRFC677 DIN for CRS60, CRL60 & QCRL60
	Round	Round
7 - 9	DRFC673-R09	-
9 - 11	DRFC673-R11	-
11 - 13	DRFC673-R13*	-
13 - 15	DRFC673-R15*	-
15 - 17	DRFC673-R17*	-
17 - 19	DRFC673-R19*	-
19 - 21	DRFC673-R21*	DRFC677-R21*
21 - 23	DRFC673-R23*	DRFC677-R23*
23 - 25	DRFC673-R25*	DRFC677-R25*
25 - 27	DRFC673-R27*	DRFC677-R27*
27 - 29	DRFC673-R29*	DRFC677-R29*
29 - 31	DRFC673-R31*	DRFC677-R31*
31 - 33	DRFC673-R33*	DRFC677-R33*
33 - 35	DRFC673-R35*	DRFC677-R35*
35 - 37	DRFC673-R37*	DRFC677-R37*
37 - 39	DRFC673-R39*	DRFC677-R39*
39 - 41	DRFC673-R41*	DRFC677-R41*
41 - 43	DRFC673-R43*	DRFC677-R43*
43 - 45	DRFC673-R45	DRFC677-R45*
45 - 47	-	DRFC677-R47*
47 - 49	-	DRFC677-R49*
49 - 51	-	DRFC677-R51*
51 - 53	-	DRFC677-R53*
53 - 55	-	DRFC677-R55*
55 - 57	-	DRFC677-R57*
57 - 59	-	DRFC677-R59*
59 - 61	-	DRFC677-R61*
61 - 63	-	DRFC677-R63
63 - 65	-	DRFC677-R65

*Available as full grip & smooth specification, otherwise can only be supplied in smooth specification

Varibore Collets for CRS36, CRL42, QCRL42, CRL60, QCRL60, CRL80 & QCRL80 Collet Chucks

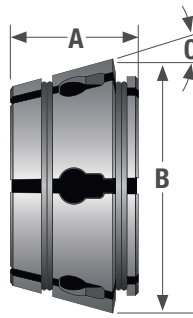

Varibore Collets - Type: DIN 6343

- Round, Hexagon or Square
- Specify which gripping surface you require – Supergrip Serrations (Heavy duty), Annular serrations or Smooth
- Other shapes available upon request

Dimensions (Metric)

Part No.	A	B	C
D671	38	56.5	14.75°
D673	39	61.5	14.75°
D677	45	85.5	14.75°
D660	48	1087.5	14.75°

Gripping Range mm	D671 DIN for CRS36			D673 DIN for CRL42 & QCRL42			D677 DIN for CRL60 & QCRL60			D660 DIN for CRL80 & QCRL80	
	Round	Hexagon	Square	Round	Hexagon	Square	Round	Hexagon	Square	Round	Hexagon
4 - 6	D671-R06	D671-X06	D671-S06	D673-R06	D673-X06	D673-S06	-	-	-	-	-
6 - 8	D671-R08	D671-X08	D671-S08	D673-R08	D673-X08	D673-S08	D677-R08	D677-X08	D677-S08	-	-
8 - 10	D671-R10	D671-X10	D671-S10	D673-R10	D673-X10	D673-S10	D677-R10	D677-X10	D677-S10	-	-
10 - 12	D671-R12	D671-X12	D671-S12	D673-R12	D673-X12	D673-S12	D677-R12	D677-X12	D677-S12	-	-
12 - 14	D671-R14	D671-X14	D671-S14	D673-R14	D673-X14	D673-S14	D677-R14	D677-X14	D677-S14	D660-R14	D660-X14
14 - 16	D671-R16	D671-X16	D671-S16	D673-R16	D673-X16	D673-S16	D677-R16	D677-X16	D677-S16	D660-R16	D660-X16
16 - 18	D671-R18	D671-X18	D671-S18	D673-R18	D673-X18	D673-S18	D677-R18	D677-X18	D677-S18	D660-R18	D660-X18
18 - 20	D671-R20	D671-X20	D671-S20	D673-R20	D673-X20	D673-S20	D677-R20	D677-X20	D677-S20	D660-R20	D660-X20
20 - 22	D671-R22	D671-X22	D671-S22	D673-R22	D673-X22	D673-S22	D677-R22	D677-X22	D677-S22	D660-R22	D660-X22
22 - 24	D671-R24	D671-X24	D671-S24	D673-R24	D673-X24	D673-S24	D677-R24	D677-X24	D677-S24	D660-R24	D660-X24
24 - 26	D671-R26	D671-X26	-	D673-R26	D673-X26	D673-S26	D677-R26	D677-X26	D677-S26	D660-R26	D660-X26
26 - 28	D671-R28	D671-X28	-	D673-R28	D673-X28	D673-S28	D677-R28	D677-X28	D677-S28	D660-R28	D660-X28
28 - 30	D671-R30	-	-	D673-R30	D673-X30	D673-S30	D677-R30	D677-X30	D677-S30	D660-R30	D660-X30
30 - 32	D671-R32	-	-	D673-R32	D673-X32	-	D677-R32	D677-X32	D677-S32	D660-R32	D660-X32
32 - 34	D671-R34	-	-	D673-R34	D673-X34	-	D677-R34	D677-X34	D677-S34	D660-R34	D660-X34
34 - 36	D671-R36	-	-	D673-R36	D673-X36	-	D677-R36	D677-X36	D677-S36	D660-R36	D660-X36
36 - 38	-	-	-	D673-R38	-	-	D677-R38	D677-X38	D677-S38	D660-R38	D660-X38
38 - 40	-	-	-	D673-R40	-	-	D677-R40	D677-X40	D677-S40	D660-R40	D660-X40
40 - 42	-	-	-	D673-R42	-	-	D677-R42	D677-X42	D677-S42	D660-R42	D660-X42
42 - 44	-	-	-	-	-	-	D677-R44	D677-X44	-	D660-R44	D660-X44
44 - 46	-	-	-	-	-	-	D677-R46	D677-X46	-	D660-R46	D660-X46
46 - 48	-	-	-	-	-	-	D677-R48	D677-X48	-	D660-R48	D660-X48
48 - 50	-	-	-	-	-	-	D677-R50	D677-X50	-	D660-R50	D660-X50
50 - 52	-	-	-	-	-	-	D677-R52	D677-X52	-	D660-R52	D660-X52
52 - 54	-	-	-	-	-	-	D677-R54	-	-	D660-R54	D660-X54
54 - 56	-	-	-	-	-	-	D677-R56	-	-	D660-R56	D660-X56
56 - 58	-	-	-	-	-	-	D677-R58	-	-	D660-R58	D660-X58
58 - 60	-	-	-	-	-	-	D677-R60	-	-	D660-R60	D660-X60
60 - 62	-	-	-	-	-	-	-	-	-	D660-R62	D660-X62
62 - 64	-	-	-	-	-	-	-	-	-	D660-R64	D660-X64
64 - 66	-	-	-	-	-	-	-	-	-	D660-R66	D660-X66
66 - 68	-	-	-	-	-	-	-	-	-	D660-R68	D660-X68
68 - 70	-	-	-	-	-	-	-	-	-	D660-R70	-
70 - 72	-	-	-	-	-	-	-	-	-	D660-R72	-
72 - 74	-	-	-	-	-	-	-	-	-	D660-R74	-
74 - 76	-	-	-	-	-	-	-	-	-	D660-R76	-
76 - 78	-	-	-	-	-	-	-	-	-	D660-R78	-
78 - 80	-	-	-	-	-	-	-	-	-	D660-R80	-

Emergency Collets with soft face and pilot hole is available for all types

QC & C Series Standard Accessories

Work Stops

- Stops can be provided to allow for accurate z-axis positioning of short workpieces within the collet chuck.
- A threaded stud is provided for easy adjustment to suit your work piece
- All stops are easily installed from the front face utilising a side bolt to hold the stop securely in place.
- These stops can be installed on all QC & C series collet chucks.
- Full length spindle stops can also be provided for long work pieces, these can utilise the entire length of your machine spindle, please contact your Klamp supplier to see the maximum length stop your machine could accommodate.

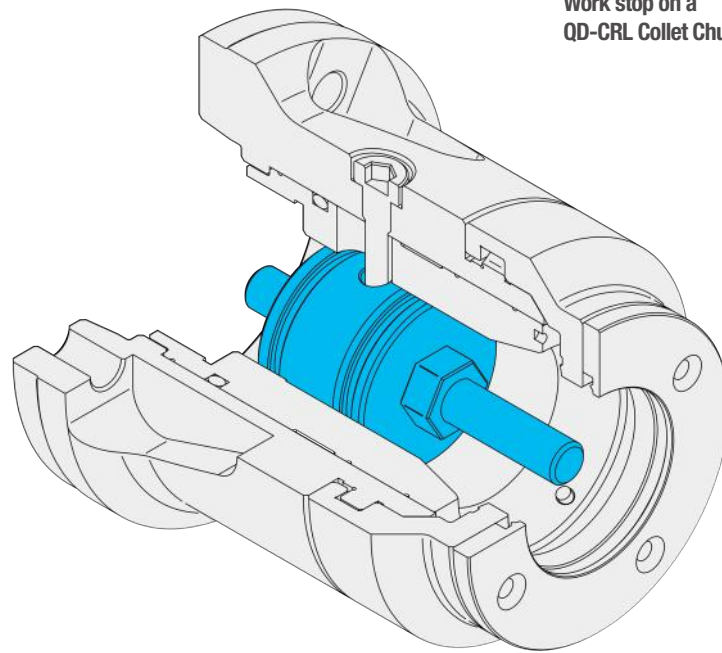

Work stop on a QD-CRL Collet Chuck

Spring Ejectors

- Standard spring ejectors for QC & C series are used for second-spindle operations to expel finished workpieces into the parts catcher.
- Many variants of spring ejector are available to suit your production process.
- Spring ejectors can be installed on all QC & C series collet chucks.
- Full length hydraulic or pneumatic ejectors can also be provided for long work pieces, this can utilise the entire length of your machine spindle, please contact your Klamp supplier to see the maximum length stop your machine could accommodate.

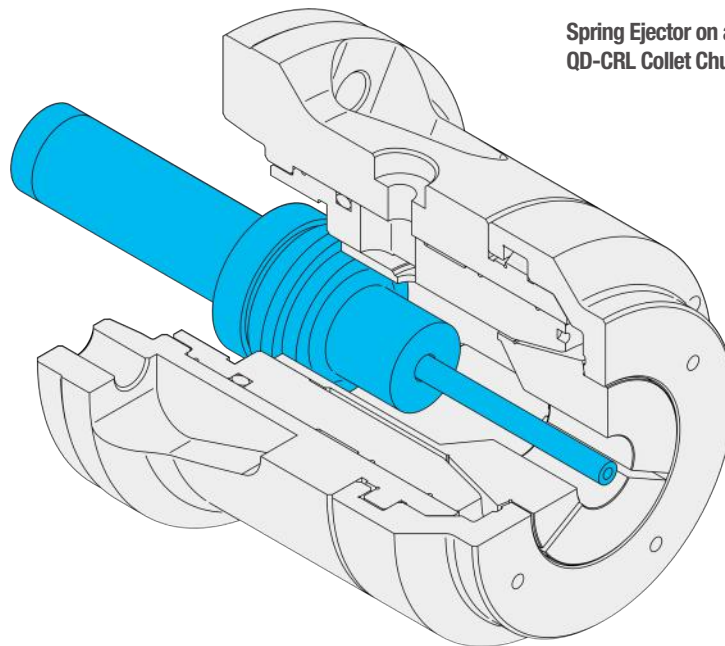

Spring Ejector on a QD-CRL Collet Chuck