

仕様 SPECIFICATIONS	
前出精度 INDEXING ACCURACY	20 sec以内
再現精度 REPEATABILITY	4 sec以内
テーブル最高回転速度 MAXIMUM ROTATION SPEED	41.6 min ⁻¹ (モータ3000 min ⁻¹)
許容最大空圧力 MAXIMUM PNEUMATIC PRESS	0.6 MPa
クランプトルク CLAMPING TORQUE	450N·m (静摩擦0.5MPa)
許容積載質量 ALLOWABLE MASS OF WORK	横 160 kg 立 80 kg
許容積載ワーク径 ALLOWABLE WORK DIA.	φ165 mm
総減速比 TOTAL REDUCTION RATIO	1/72
製品質量 MASS OF ROTARY TABLE	56 kg
慣性モーメント (モータに接続) MACHINE INERTIA (REMOVED TO MOTOR SHEET)	0.000425kg·m ² (0.0043kg·cm ²)

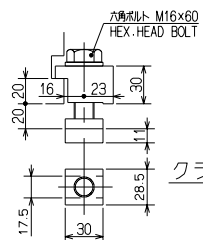
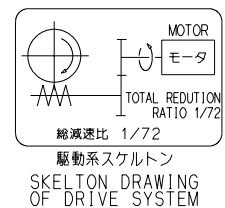
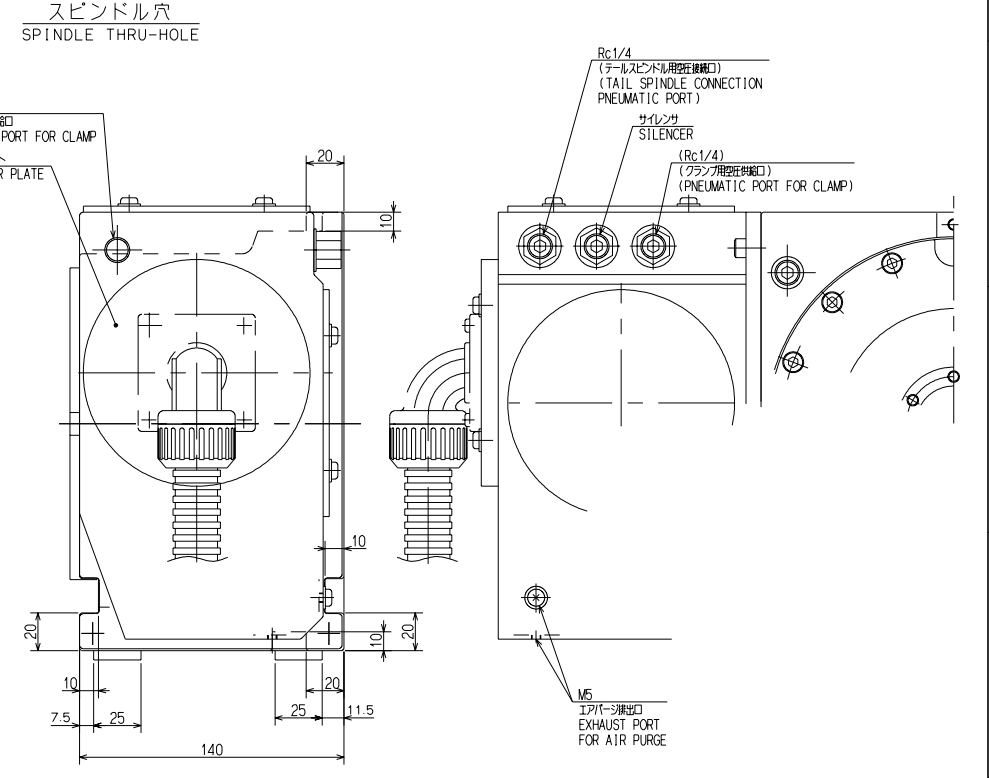
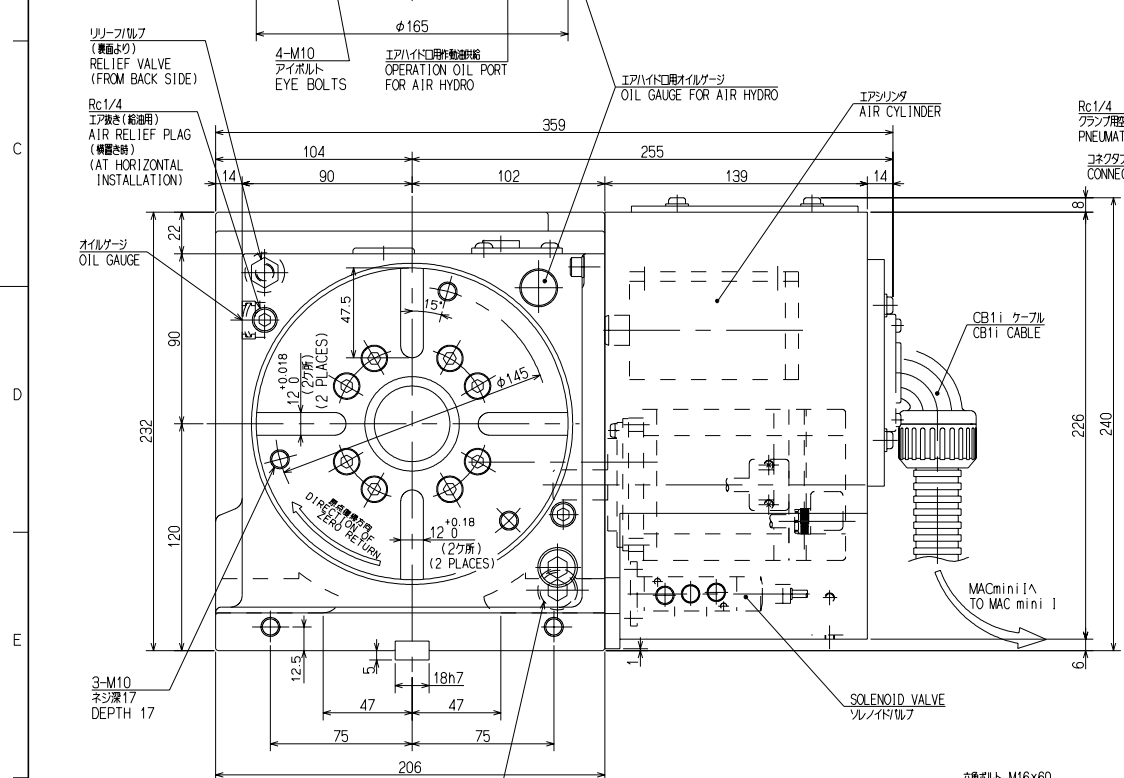

クランプ器具 付属品4組
CLAMPING PARTS
4 SETS
(S=1/3)

CAREER			SCALE	TYPE	TMX160B20	WEIGHT	k.g
MANAGER	CHIEF	DRAWN BY	1:2	NAME	NCテーブル NC ROTARY TABLE		
KITAGAWA IRON WORKS CO., LTD.			3RD ANGLE	NAME	TMX160B20 ガイエイ OUTSIDE VIEW		
DATE			DRW NO.	61E 24 7762 1			