

ISSUE	DATE

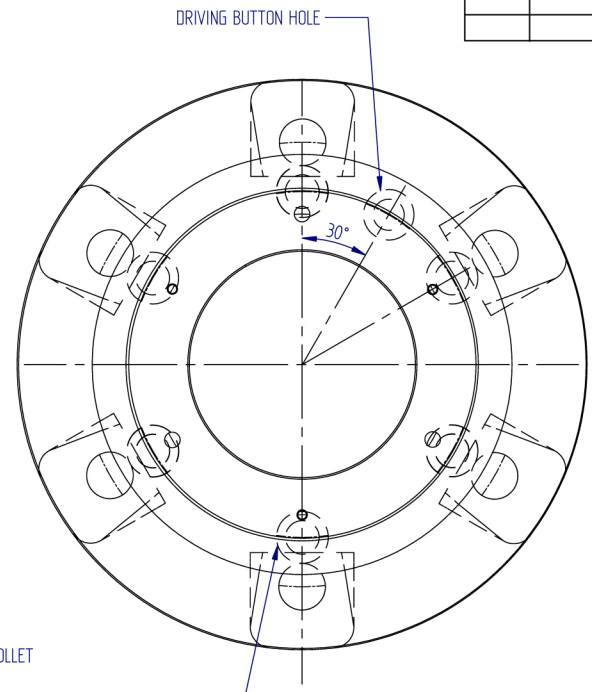
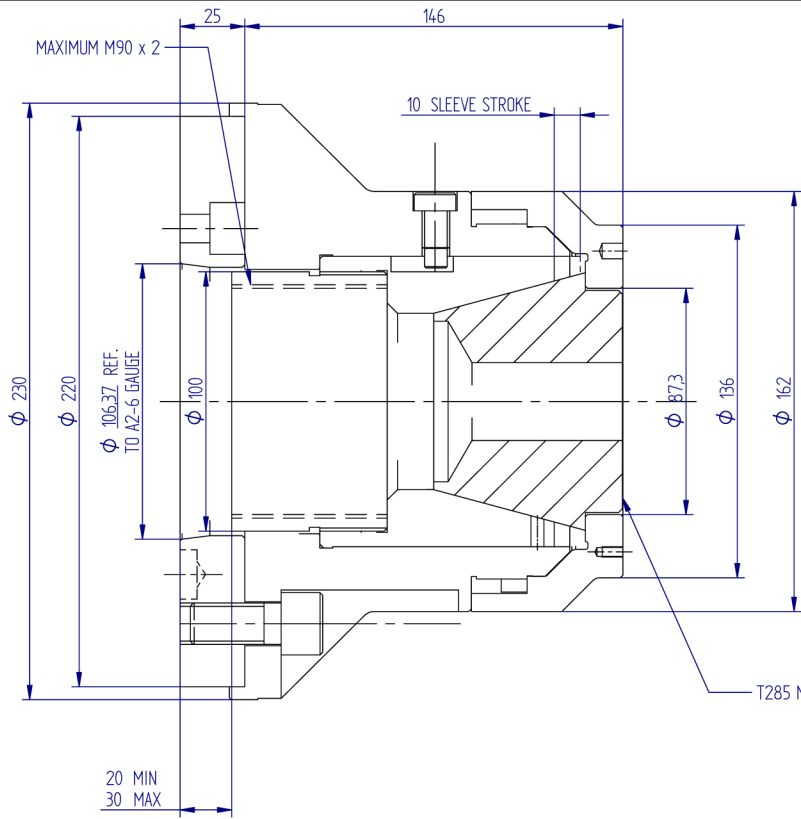

T285 MULTIBORE COLLET

6 - MOUNTING BOLT HOLES
ON $\phi 133.4$ P.C.
TO SUIT M12 CAP SCREWS

KITAGAWA EUROPE LTD.

RANGE AS SPECIFIED	MACHINING TOLERANCES							
	NOMINAL DIMENSION							
	≤ 0.5 ... 3	> 3 ... 6	≤ 6 ... 30	> 30 ... 120	≤ 120 ... 400	> 400 ... 1000	≤ 1000 ... 2000	> 2000
ALL DIMENSION IN mm								
FINE	0.05	0.05	0.1	0.15	0.2	0.3	0.5	
MEDIUM	0.1	0.1	0.2	0.3	0.5	0.8	1.2	
COARSE	0.2	0.3	0.5	0.8	1.2	2	3	
VERY COARSE		0.5	1	1.5	2	3	4	

DRAWN	DPB
DATE	10/12/04
SCALE	
CHECK	

TITLE
KITAGAWA QCRS66-A6
QUICK CHANGE COLLET CHUCK
TO SUIT T285 COLLETS
DRAWING NO.
QCRS66-A6

ISSUE	DATE

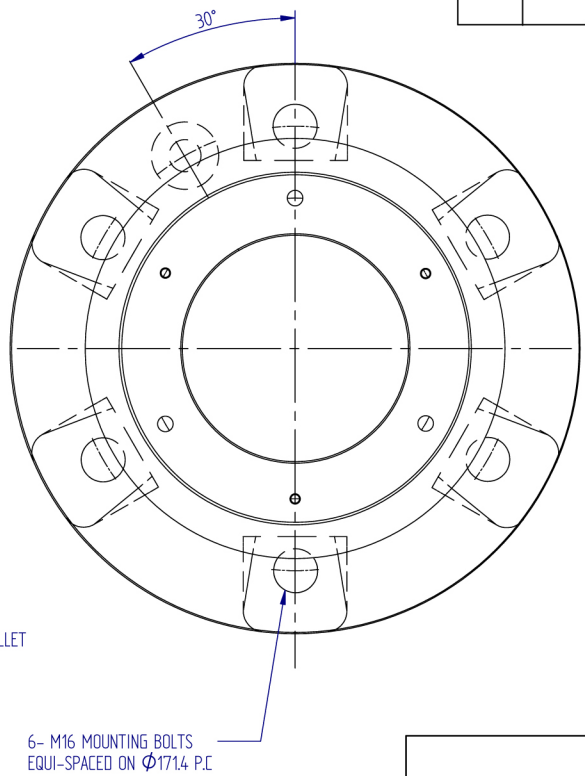
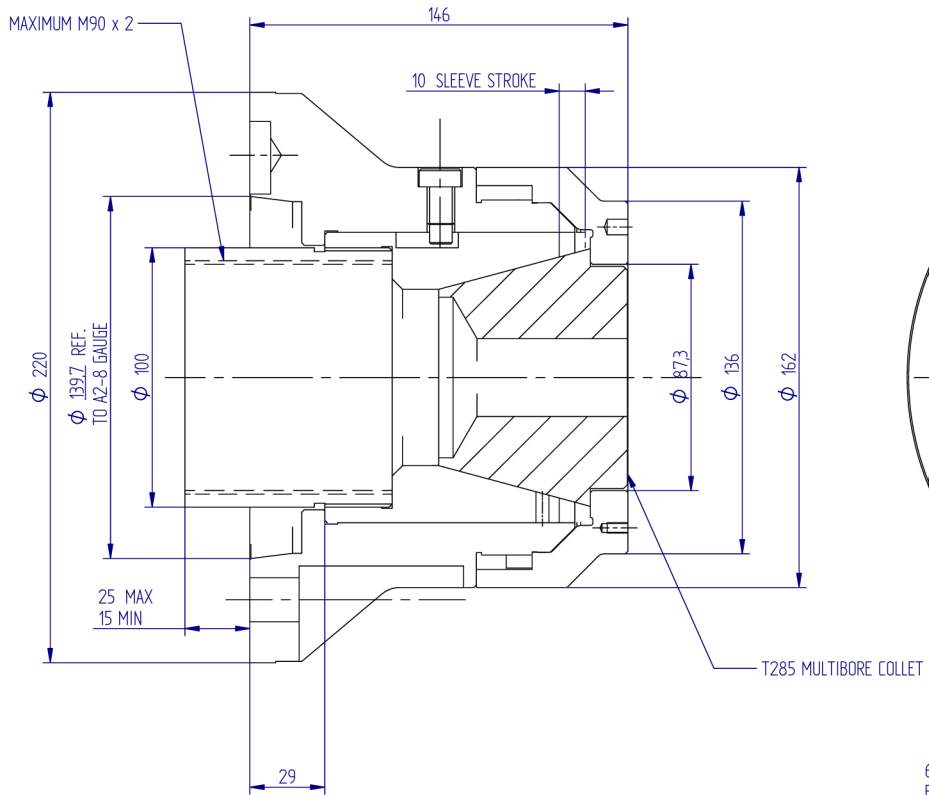

KITAGAWA EUROPE LTD.

RANGE AS SPECIFIED	MACHINING TOLERANCES							
	NOMINAL DIMENSION							
	≤ 0.5 ... 3	> 3 ... 6	> 6 ... 30	> 30 ... 120	> 120 ... 400	> 400 ... 1000	> 1000 ... 2000	
	ALL DIMENSION IN mm							
FINE	0.05	0.05	0.1	0.15	0.2	0.3	0.5	
MEDIUM	0.1	0.1	0.2	0.3	0.5	0.8	1.2	
COARSE	0.2	0.3	0.5	0.8	1.2	2	3	
VERY COARSE		0.5	1	1.5	2	3	4	

DRAWN	DPB
DATE	18/09/04
SCALE	
CHECK	

TITLE
KITAGAWA QCRS66-A8
QUICK CHANGE COLLET CHUCK
TO SUIT T285 COLLETS
DRAWING NO.
QCRS66-A8