

仕様 SPECIFICATIONS	
引出精度 INDEXING ACCURACY	20 sec以内
再現精度 REPEATABILITY	4 sec以内
テーブル最高回転速度 MAXIMUM ROTATION SPEED	25.0 min <sup>-1</sup> (E=2 3000 min <sup>-1</sup> )
クランプトルク CLAMPING TORQUE	1100N·m (E=2 1100N·m)
許容最大空圧力 MAXIMUM PNEUMATIC PRESS	0.6 MPa
許容積載質量 ALLOWABLE MASS OF WORK	125 kg
許容積載ワーク径 ALLOWABLE WORK DIA.	φ250 mm
総減速比 TOTAL REDUCTION RATIO	1/120
製品質量 MASS OF ROTARY TABLE	135 kg
慣性モーメント MACHINE INERTIA (BASED TO MOTOR SHAFT)	kgm <sup>2</sup> (kgfcm <sup>2</sup> )

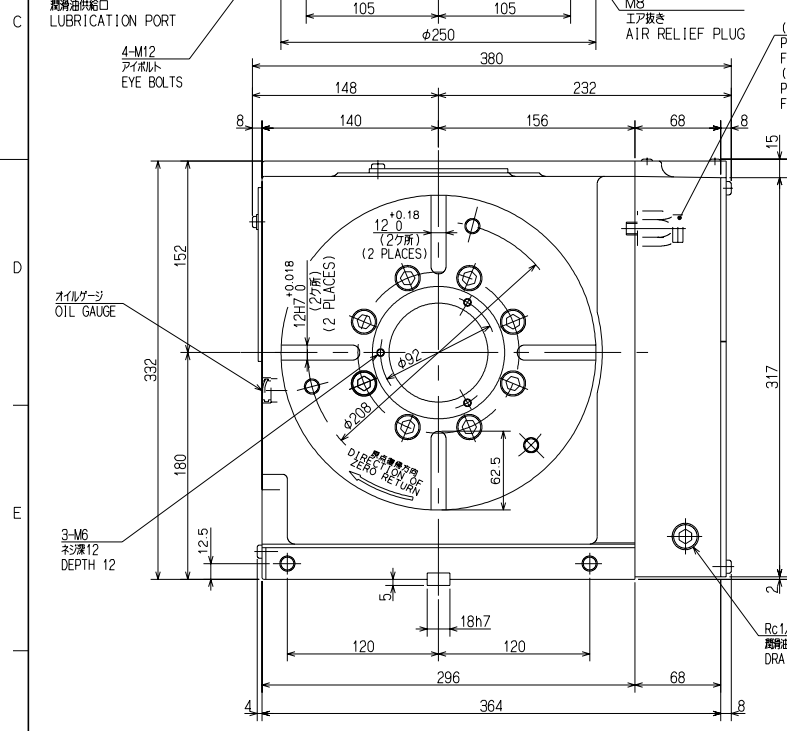

(手動側) クランプ検出用プレッシャースイッチ PRESSURE SWITCH FOR CLAMP DETECTION  
 (自動側) アンクランプ検出用プレッシャースイッチ PRESSURE SWITCH FOR UNCLAMP DETECTION

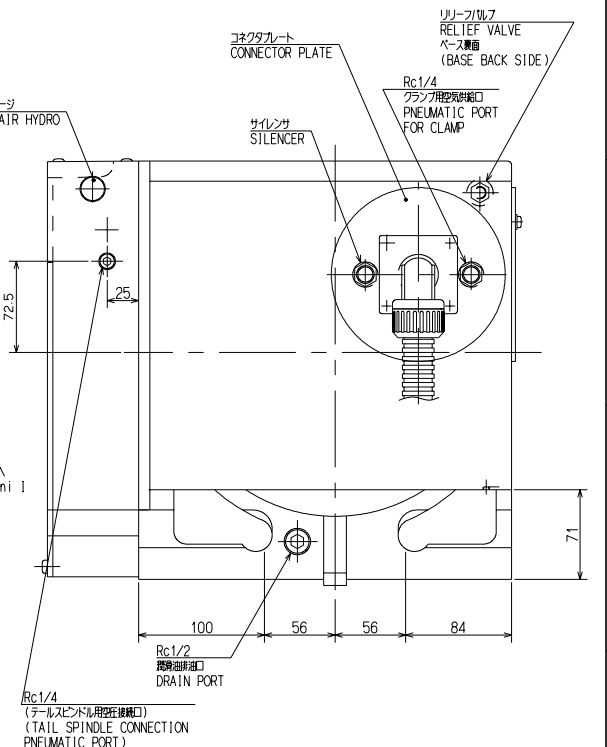
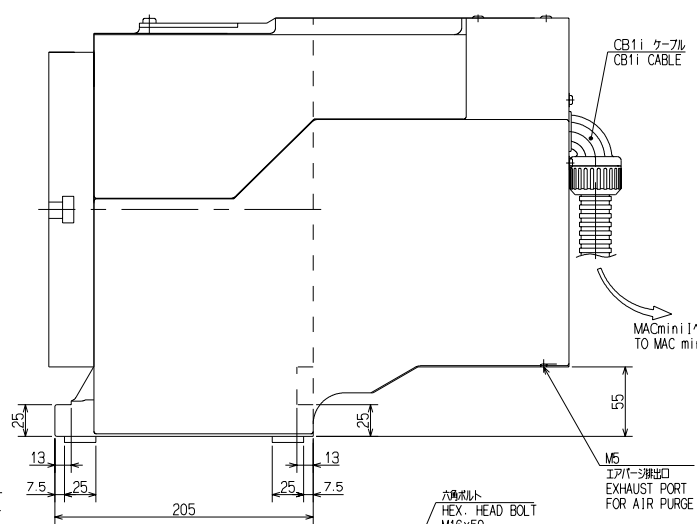
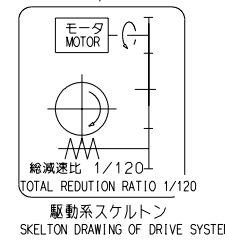

CAREER	SCALE	TYPE	TBx250B20	WEIGHT	kg
MANAGER	1:3	NC	テーブル NC	ROTARY TABLE	
CHIEF	NAME	TBx250B20 ガイウェイ			
DRAWN BY	OUTSIDE VIEW				
KITAGAWA IRON WORKS CO., LTD.	DATE	DRW NO.	61E 24 4458	2	