



CHUCK

Large Thru-Hole Power Chuck BB200 series

Stable machining even for large diameter bar material
Universally recognised standard chuck



- Standard Soft Jaw can be used for B-200 series as well
- Large through-hole
6 inch ϕ 53 · 8 inch ϕ 66
10inch ϕ 81 · 12inch ϕ 106
- * CE correspondence

Dimensional Drawings

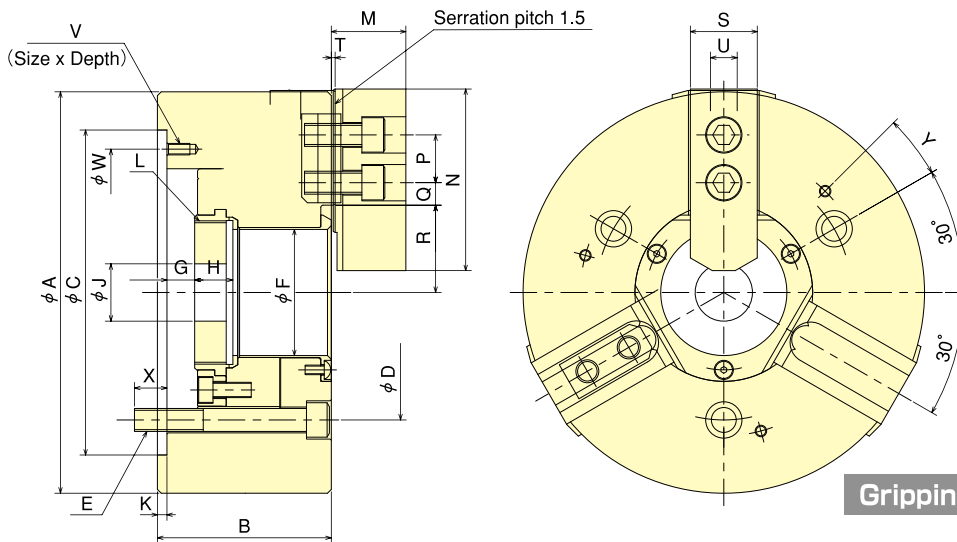

Gripping Characteristic Graphs

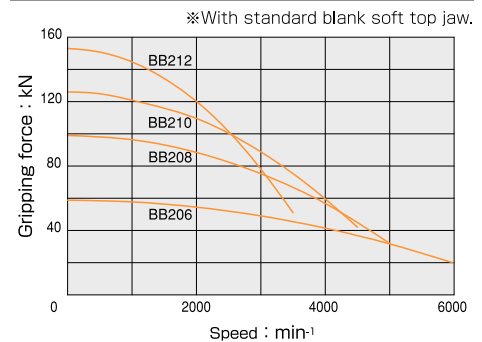

Dimensions

※Blank draw nut equipped.

Dimensions Model	A	B	C (H6)	D	E	F	G max.	G min.	H	J	K	L max.	M	N	P	Q max.	Q min.	R max.	R min.	S	T	U	V	W	X	Y
BB206	170	81	140	104.8	3-M10	53	11	-1	17.5	20	5	M60x2.0	33.2	72	20	21.25	10.75	36	33.25	31	2	12	M6x10	116	16	-30°
BB208	210	91	170	133.4	3-M12	66	14.5	-1.5	20	30	5	M75x2.0	39	95	25	23.75	11.75	45.7	42	35	2	14	M6x12	150	17	15°
BB210	254	100	220	171.4	3-M16	81	8.5	-10.5	25	45	5	M90x2.0	43.2	110	30	32.25	14.25	54	49.6	40	2	16	M8x15	190	22	-15°
BB212	315	108	300	235	3-M20	106	8	-15	28	50	6	M115x2.0	51.7	111	30	45.75	15.75	67.8	62.5	50	2.5	21	M10x16	260	29	-15°

Specifications

Specifications Model	Gripping range mm	Jaw Stroke (diameter) mm	Plunger Stroke mm	Max. input kN (kgf)	Max. static gripping Force kN (kgf)	Max. Speed min⁻¹	Mass (with standard jaws) kg	Moment of inertia kg·m²	Compatible cylinder	Max. setting hydraulic pressure MPa (kgf/cm²)	Standard soft jaw
BB206	170 19	5.5	12	20.0 (2039)	58.5 (5965)	6000	11.7	0.050	SS1453K	1.88 (19.2)	SB06B1
BB208	210 23	7.4	16	32.0 (3263)	99.0 (10095)	5000	23.0	0.143	SS1666K	2.34 (23.9)	SB08B1
BB210	254 41	8.8	19	48.8 (4976)	126.0 (12848)	4500	31.8	0.312	SS1881K	3.09 (31.5)	SB10B1
BB212	315 47	10.6	23	59.0 (6016)	153.0 (15601)	3500	52.0	0.736	SS2110K	2.94 (30.0)	SB12N1



CHUCK

Large Thru-Hole Power Chuck (Direct Mount) BB200A series

Chuck Adaptor is equipped to suit Spindle Nose
Universally recognised standard chuck

* CE correspondence



Standard Chuck

Dimensional Drawings

Fig.2

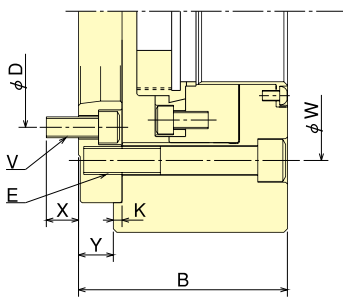
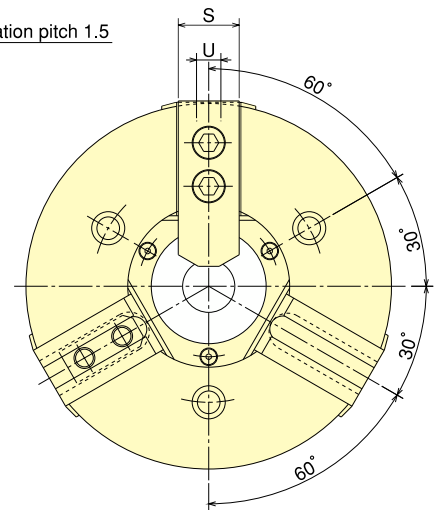
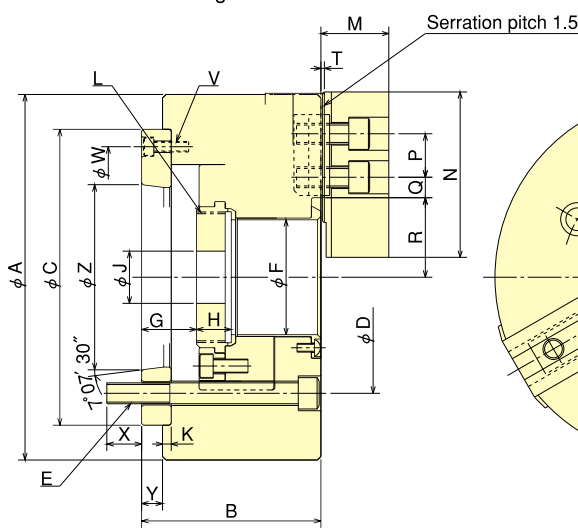
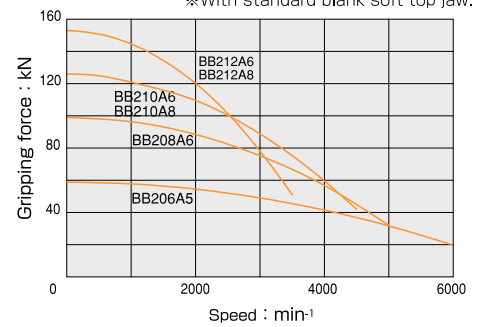

Fig.1



Gripping Characteristic Graphs

*With standard blank soft top jaw.



Dimensions *BB210A6, BB212A6, and BB212A8 are based on Fig. 2. *Blank draw nut equipped.

Dimensions Model	A	B	C	D	E	F	G max.	G min.	H	J	K	L max.	M	N	P	Q max.	Q min.	R max.	R min.	S	T	U	V	W	X	Y	Z
BB206A5	170	91	140	104.8	3-M10	53	26	14	17.5	20	5	M60x2.0	33.2	72	20	21.25	10.75	36	33.25	31	2	12	3-M6	116	16	10	82.563
BB208A6	210	103	170	133.4	3-M12	66	31.5	15.5	20	30	5	M75x2.0	39	95	25	23.75	11.75	45.7	42	35	2	14	3-M6	150	20	12	106.375
BB210A6	254	120	220	133.4	3-M16	81	33.5	14.5	25	45	5	M90x2.0	43.2	110	30	32.25	14.25	54	49.6	40	2	16	6-M12	171.4	18.5	20	106.375
BB210A8	254	113	220	171.4	3-M16	81	26.5	7.5	25	45	5	M90x2.0	43.2	110	30	32.25	14.25	54	49.6	40	2	16	3-M8	190	24	13	139.719
BB212A6	315	148	300	133.4	3-M20	106	54	31	28	50	6	M115x2.0	51.7	111	30	45.75	15.75	67.8	62.5	50	2.5	21	9-M12	235	24	40	106.375
BB212A8	315	135	300	171.4	3-M20	106	41	18	28	50	6	M115x2.0	51.7	111	30	45.75	15.75	67.8	62.5	50	2.5	21	6-M16	235	24	27	139.719

Specifications

Specifications Model	Gripping range mm		Jaw Stroke (diameter) mm	Plunger Stroke mm	Max. input kN (kgf)	Max. static gripping force kN (kgf)	Max. Speed min⁻¹	Mass (with standard jaws) kg	Moment of inertia kg·m²	Compatible cylinder	Max. setting hydraulic pressure MPa (kgf/cm²)	Standard soft jaw
BB206A5	170	19	5.5	12	20.0 (2039)	58.5 (5965)	6000	12.7	0.051	SS1453K	1.88 (19.2)	SB06B1
BB208A6	210	23	7.4	16	32.0 (3263)	99.0 (10095)	5000	25.0	0.143	SS1666K	2.34 (23.9)	SB08B1
BB210A6	254	41	8.8	19	48.8 (4976)	126.0 (12848)	4500	37.6	0.355	SS1881K	3.09 (31.5)	SB10B1
BB210A8	254	41	8.8	19	48.8 (4976)	126.0 (12848)	4500	34.7	0.317	SS1881K	3.09 (31.5)	SB10B1
BB212A6	315	47	10.6	23	59.0 (6016)	153.0 (15601)	3500	68.5	0.945	SS2110K	2.94 (30.0)	SB12N1
BB212A8	315	47	10.6	23	59.0 (6016)	153.0 (15601)	3500	66.4	0.933	SS2110K	2.94 (30.0)	SB12N1