

NC ROTARY TABLE

High Performance NC Rotary Table - Back side mounted motor

TBX series

**TBX160·TBX200
TBX250·TBX320**

High performance range with back mounted motor to reduce interference with machining area

- High rigidity for heavy cutting
- High accuracy
- Space saving
- Integrated air booster provides high clamping torque (comparable to hydraulic) from a standard air supply
- Air booster or direct hydraulic clamping options available

*CE correspondence



TBX320

Sample Application

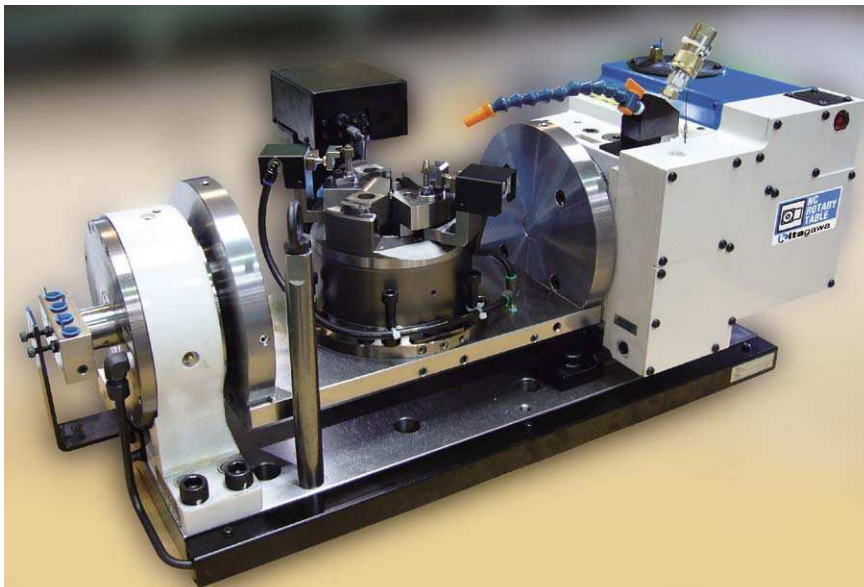

▲Space saving design reduces footprint size.

TBX

4th axis specifications				M signal specification			
TBX 160 B * * *				TBX 160 B V * *			
Type	Table Size	Design No.		Type	Table Size	Design No.	
	160·200·250·320	Motor type			160·200·250·320	Quinte specification	
		Clamping method				Clamping method	
		B: Air-Hydraulic(integrated air hydraulic booster) H: Hydraulic				B: Air-Hydraulic(integrated air hydraulic booster) H: Hydraulic	

Specifications

Model		TBX160	TBX200	TBX250	TBX320
Table dia (mm)		φ 165	φ 200	φ 250	φ 320
Register diameter on Face Plate (mm)		φ 50 H7	φ 75 H7	φ 105 H7	φ 135 H7
Spindle through hole diameter (mm)		φ 40	φ 52	φ 78	φ 110
Centre Height (mm)		120	140	180	225
Clamping method		Air-Hydraulic/Hydraulic	Air-Hydraulic/Hydraulic	Air-Hydraulic/Hydraulic	Air-Hydraulic/Hydraulic
Clamping torque (N·m) (In Pneumatic 0.5MPa / Hydraulic 3.5MPa)		450	600	1100	2600
Motor axis reduced inertia (kg·m ²)		0.00032	0.00087	0.00112	0.00147
Servomotor (for FANUC specification)		α iF 2/5000	α iF 4/5000	α iF 4/5000	α iF 8/3000
Gear ratio (Decel. Ratio in M signal)		1/72	1/90	1/90(1/120)	1/120(1/180)
Max. spindle speed	FANUC specification(for min ⁻¹ /motor 3000min ⁻¹)	41.6	33.3	33.3	25
	M signal specification(for min ⁻¹ /motor 3000min ⁻¹)	41.6	33.3	25	16.6
Allowable work inertia (kg·m ²)		0.26	0.50	0.98	2.24
Indexing accuracy (sec)		20	20	20	20
Repeatability (sec)		4	4	4	4
Mass of product (kg)		66	74	135	220
Manual Tailstock (as an option · p89 reference)		TS160RN	TS200RN	TS250RN	TS320RN
Tail Spindle (as an option · p93 reference)		TSR121A	TSR142A	TSR181A	TSR181A-45
Allowable load	Horizontal (kg)	—	—	—	—
	Vertical (kg)	80	100	125	180
Allowable load (When clamped to table)	F (kN)	10	17	21	26
	F _{XL} (N·m)	600	1100	1600	2500
	F _{XL} (N·m)	450	600	1100	2600
Allowable cutting torque	T (N·m)	240	310	730	1000

Note) 1. The switch for pressure checking is incorporated to all series except TC/DM of NC tables. 2. In case of air + hyd. clamp specification, the solenoid valve for table clamp is incorporated. 3. Neither cable nor hose is fitted between NC rotary table and machine tool... 4. Solenoid valve is not incorporated in case of hydraulic clamp method. Consequently, customer shall prepare it. 5. Because a mounting pitch varies with the machines, refer to the pitch of the table spindle size drawing on P93. 6. Each product mass is determined by a Kitagawa M signal spec.

■Dimensions [4th axis specifications]

TBX160

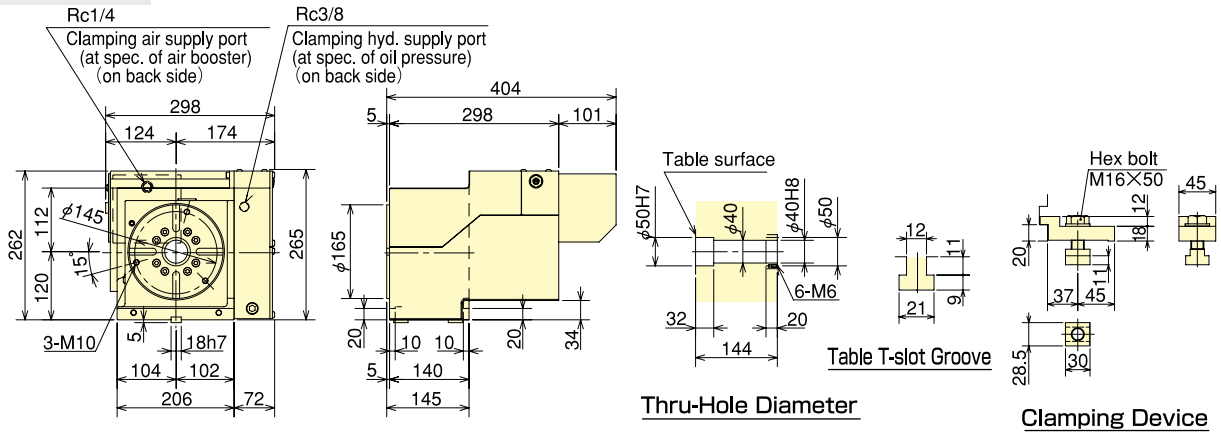

TBX200

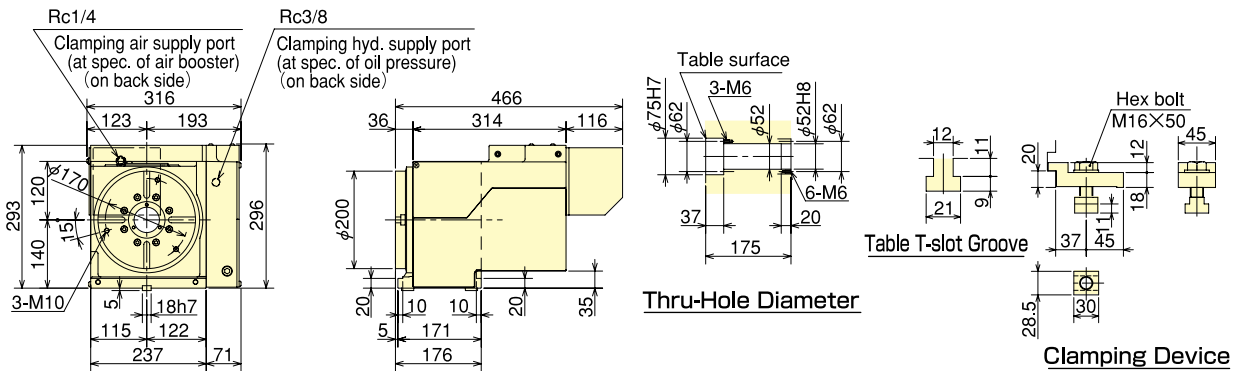

TBX250

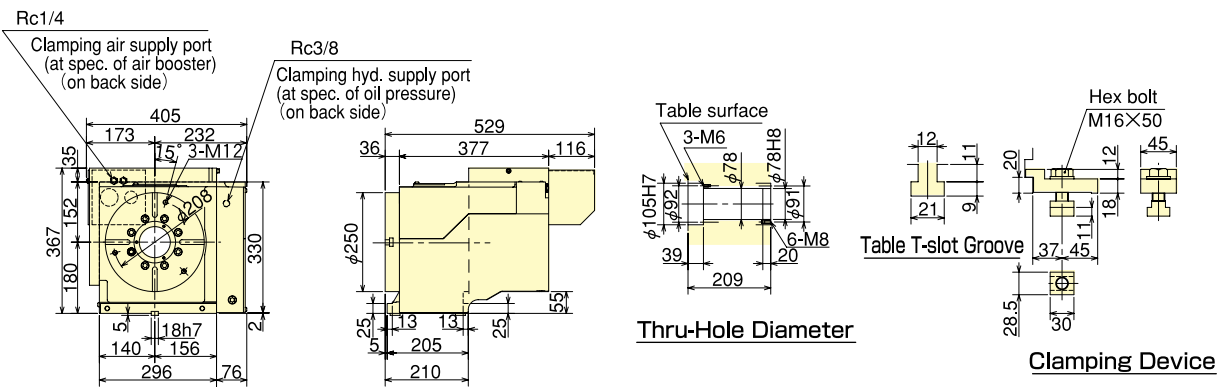

TBX320

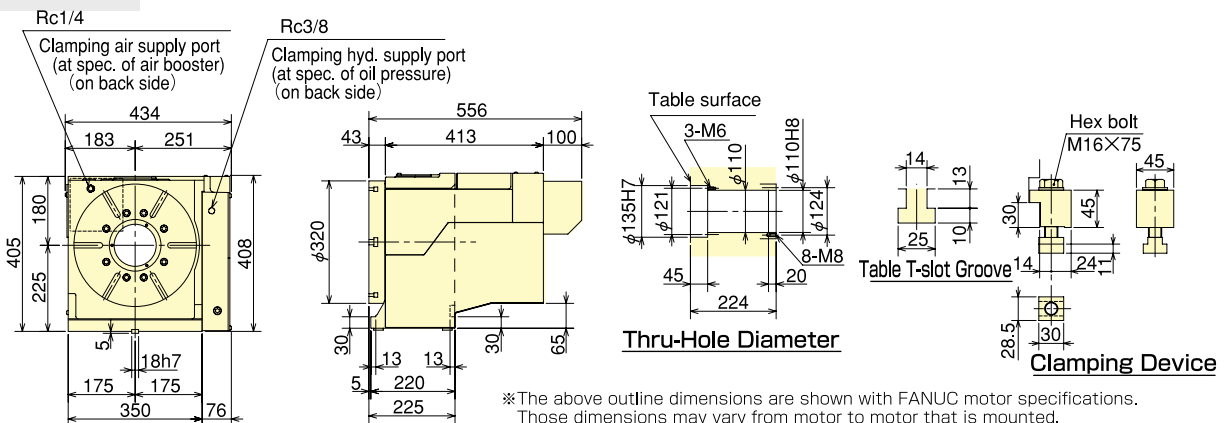

*The above outline dimensions are shown with FANUC motor specifications. Those dimensions may vary from motor to motor that is mounted.

■Dimensions [Kitagawa own controller]

*The dimensions may vary from motor to motor that is mounted.

TBX 160

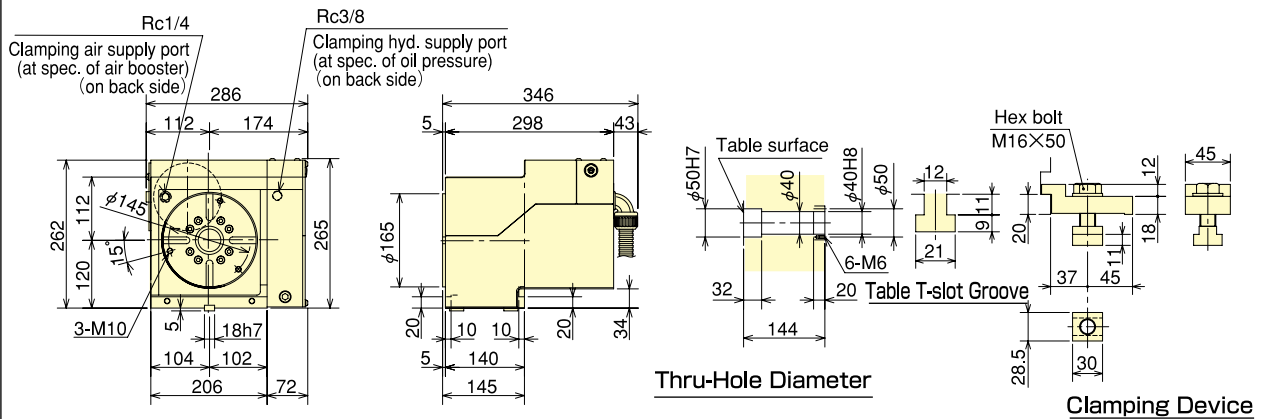

TBX200

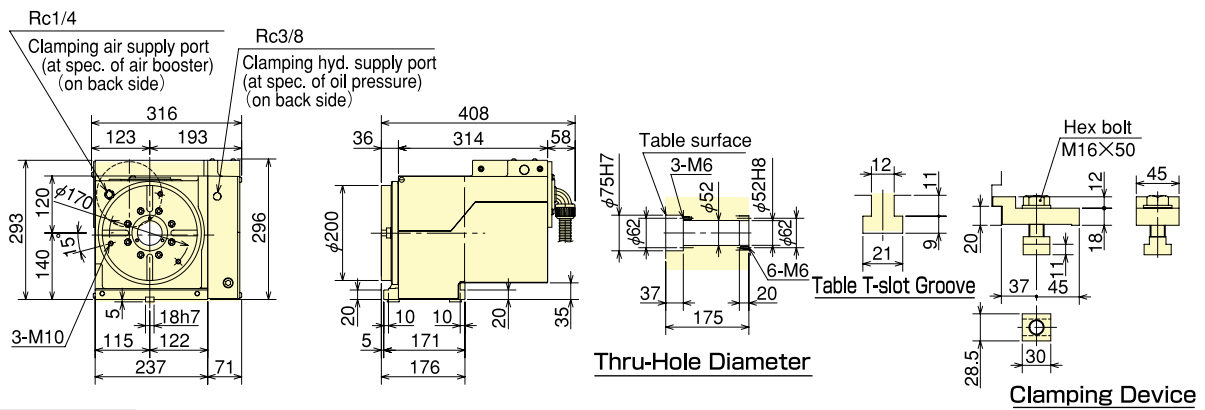

TBX250

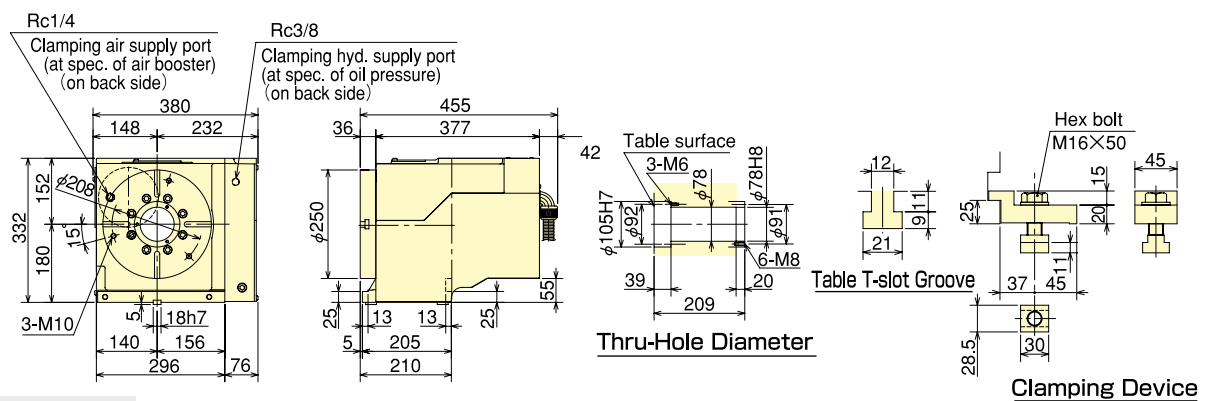

TBX320

